

# COBRA

## COBRA GARDEN TRACTOR OWNER'S MANUAL

**MODEL:** LT86MRL (TTM86)  
LT86HRL (TTM86H)  
LT92HRL (TTM92H)  
LT102HRL (TTM102H)

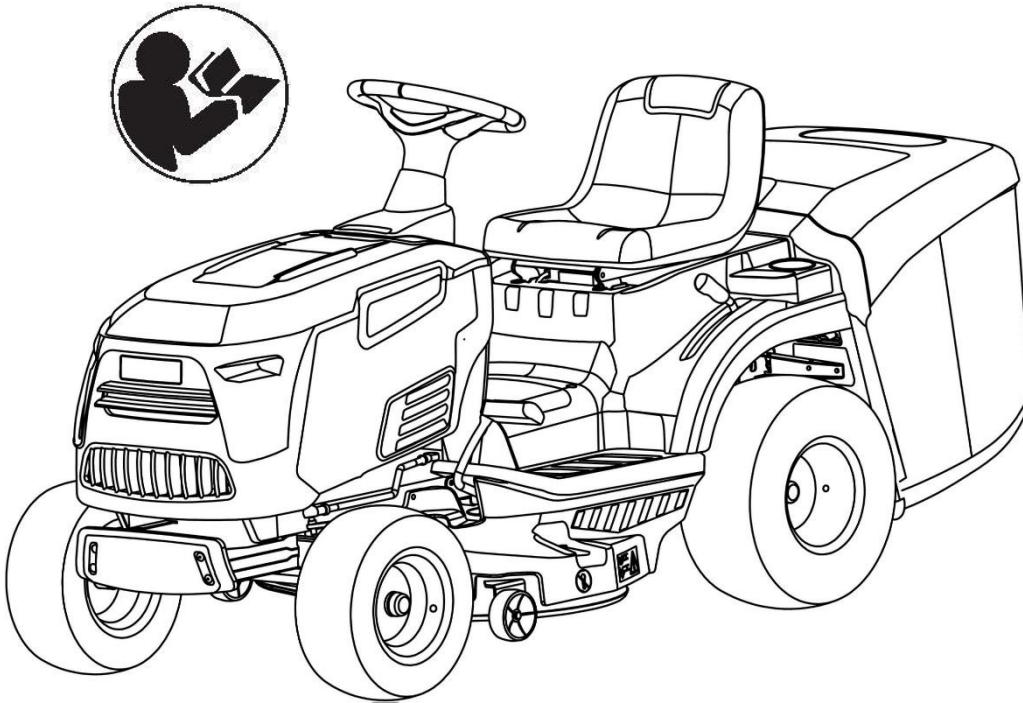

**WARNING!**

When using the machine the safety rules must be followed. For your own safety and bystanders please read these instructions before operating the machine. Please keep the instructions safe for later use.

**Cobra Garden Machinery**  
Henton and Chattell Ltd., London Road, Nottingham NG2 3HW UK  
[www.cobragarden.co.uk](http://www.cobragarden.co.uk)

# INTRODUCTION

Dear Customer,

Thank you for choosing a Cobra garden machinery product.

This manual has been written to help you become familiar with the machine and use it safely and efficiently. Do not forget that it is an integral part of the machine, so keep it close at hand for future reference and pass it on to the purchaser if you sell the machine.

The garden tractor has been designed and built in compliance with current standards, and is safe and reliable when used for cutting and collecting grass following the instructions in this manual. Always follow the instructions to ensure safe operation. If you use the machine in any other way or ignore the instructions for safe use, maintenance and repair, it is considered "**incorrect usage**". In this case, the warranty is automatically voided and the manufacturer will not be held responsible for damage or injury to yourself or others.

We continuously improve our products and as such minor modifications may result in slight differences between your garden tractor and the instruction manual. Modifications can be made to the machine without notice and without the obligation to update the manual, although the essential safety and function characteristics will remain unaltered. If in doubt, do not hesitate to contact your dealer. And now enjoy your Cobra garden tractor.

## AFTERSALES SERVICE

This manual gives all the necessary instructions for using the machine and carrying out basic maintenance.

**Any adjustments or maintenance operations not described in this manual must be carried out by your dealer or a specialised Service Centre. Both have the necessary knowledge and equipment to ensure that the work is done correctly without affecting the safety of the machine.**

This will help you keep your new purchase in peak performance and maintain its value over time. For any replacement parts, contact your Cobra dealer.

## WARNING LABELS



# IMPORTANT

The lawnmower must always be used with utmost caution. So that safety precautions and operating instructions are always readily on hand, labels have been affixed to the machine showing pictographs illustrating the main operating precautions. The labels, according to applicable safety standards, are considered an integral part of the machine, the user is therefore responsible for replacing them in the event they become detached or illegible.

## LABEL POSITION

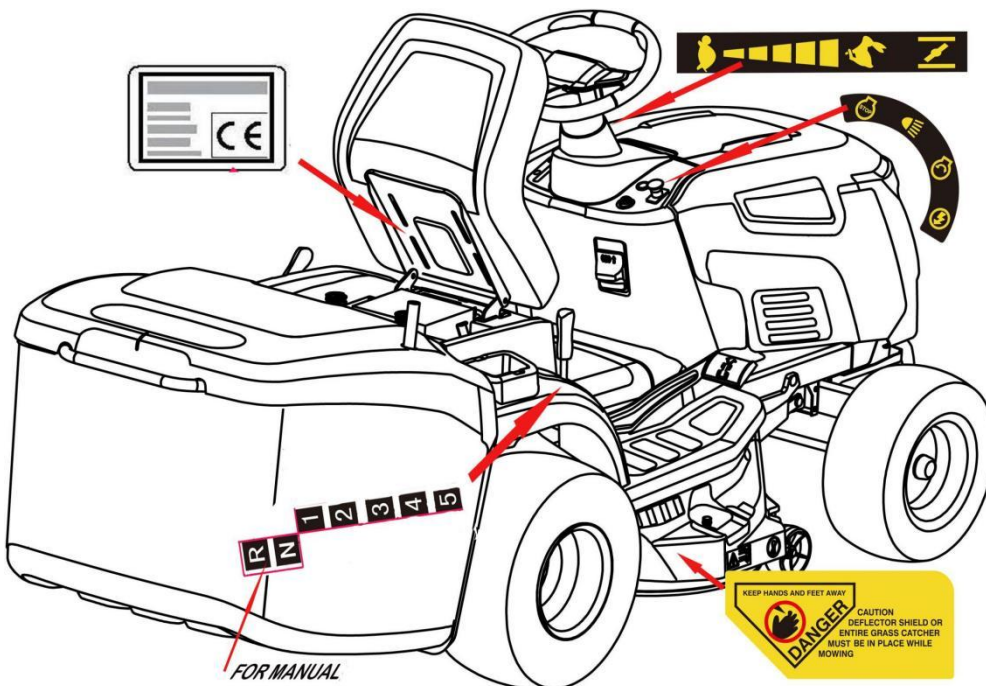
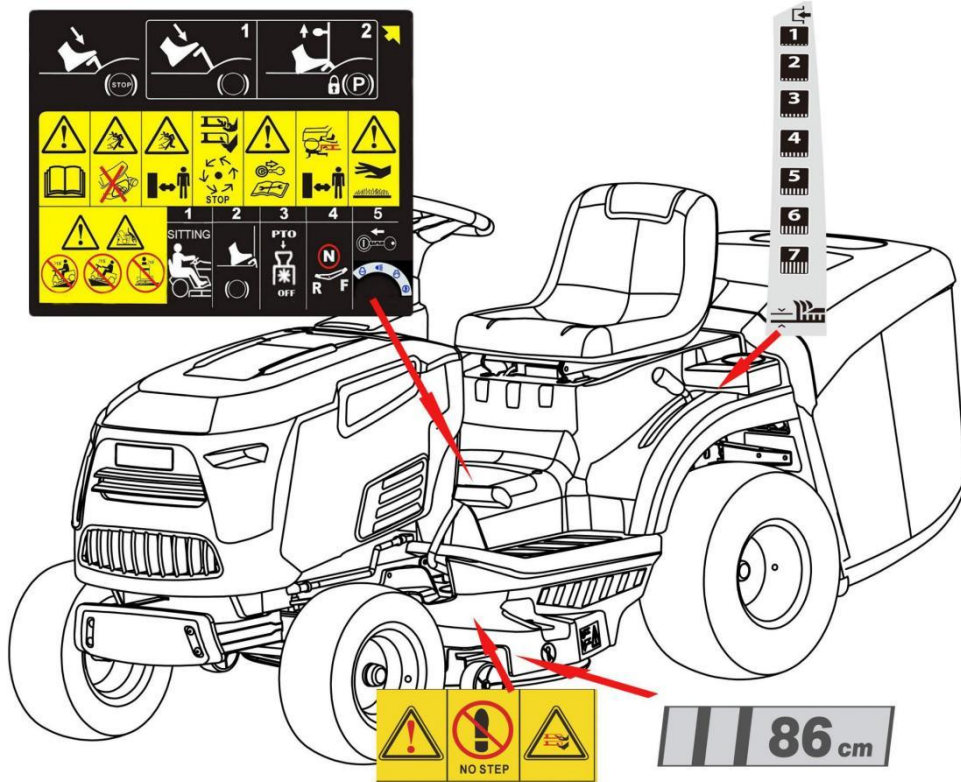

---

## TABLE OF CONTENTS

1. SAFETY .....	5
2. IDENTIFICATION OF THE MACHINE AND COMPONENTS.....	9
3. UNPACKING AND ASSEMBLY .....	11
4. CONTROLS AND INSTRUMENTS.....	17
5. HOW TO USE THE MACHINE .....	20
5.1 SAFETY RECOMMENDATIONS.....	20
5.2 WHY THE SAFETY DEVICES CUT IN.....	20
5.3 DIRECTIONS BEFORE STARTING WORK .....	20
5.4 USING THE MACHINE .....	22
5.5 USING ON SLOPING GROUND .....	25
5.6 TRANSPORTING .....	26
5.7 LAWN MAINTENANCE .....	26
6. MAINTENANCE .....	27
6.1 SAFETY RECOMMENDATIONS.....	27
6.2 SCHEDULED MAINTENANCE .....	28
6.3 CHECKS AND ADJUSTMENTS .....	29
6.4 DISMANTLING AND REPLACEMENT .....	29
6.5 LUBRICATION.....	31
7. TROUBLESHOOTING .....	32
8. SPECIFICATION.....	35
9. WARRANTY .....	37
10. EC DECLARATION .....	38

# 1. SAFETY

## 1.1 HOW TO READ THE MANUAL

Some paragraphs in the manual containing important information regarding safety and operation are emphasised in the following ways.

**NOTE** or **IMPORTANT** These give details or further information on what has already been said, in the aim to prevent damage to the machine.

**▲ WARNING!** Non-observance will result in the risk of injury to oneself or others

**▲ DANGER!** Non-observance will result in the risk of serious injury or death to oneself or others

**NOTE** Positions refer such as “front”, “back”, “left” or “right” hand side, refer to forward travel direction.

**IMPORTANT** For all operations regarding the use and maintenance of the engine not described in this manual, refer to the relevant manuals which form an integral part of all the documentation supplied with the machine.

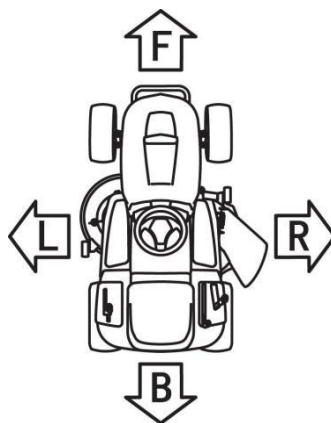

## 1.2 GENERAL SAFETY REGULATIONS

**▲ WARNING!** Read carefully before using the machine.

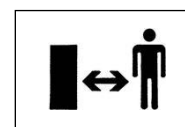

A) **TRAINING** - Read the instructions carefully.

**Be familiar with the controls and how to use the equipment properly.**

- Never let children or people unfamiliar with these instructions use the machine. Local regulations can restrict the age of the user.
- Never mow while people, especially children, or pets are nearby; Never mow while dark.
- Keep in mind that the operator or user is responsible for accidents or hazards occurring to other people or their property.
- Do not carry passengers.
- All drivers should seek and obtain professional and practical instruction. Such instruction should emphasise:
  - the need for care and concentration when working with ride-on machines;
  - you cannot use the brake to regain control of a ride-on machine sliding down a slope.

**The main reasons for loss of control are:**

- insufficient wheel grip;
- over-speeding;
- inadequate braking;
- the type of machine is unsuitable for its task;
- unawareness of the effect of ground conditions, especially slopes;
- incorrect hitching and load distribution



## B) PREPARATION



**While mowing, always wear sturdy footwear and long trousers.** Do not operate the equipment barefoot or wearing open sandals. Thoroughly inspect the area where the equipment is to be used and remove all objects which can be ejected from the machine, such as twigs, branches, stones, and other debris.



### **DANGER! Petrol is highly flammable:**

- store fuel in containers specifically designed for this purpose;
- refuel outdoors only and do not smoke while refueling;



**Add fuel before starting the engine. Never remove the cap of the fuel tank or add petrol while the engine is running or when the engine is hot;**



- if you spill petrol, do not start the engine and move the machine away from the area of spillage. Do not create any source of ignition until the petrol vapors have evaporated;
- put back and tighten all fuel tank and container caps securely.
- Replace faulty silencers.
- **Before use**, always inspect the machine to check that the blades, blade bolts and cutter assembly are not worn or damaged. Replace worn or damaged blades and bolts in sets to preserve balance.
- On multi-bladed machines, remember that the rotation of one blade can cause other blades to rotate.

**NOTICE! – Always check the engine oil is the correct level before starting. Check the engine manual for further details.**

## C) OPERATION



- 1) Do not start the engine in a confined space where dangerous carbon monoxide fumes can collect.
- 2) Mow only in daylight or good artificial light.
- 3) Before starting the engine, disengage the blades and shift into neutral.
- 4) Do not use the machine on slopes with longitudinal gradients of more than 15°(27%). Do not use the machine on slopes with lateral gradients above 10°(18%).
- 5) Remember there is no such thing as a “safe” slope. Travelling on grass slopes requires particular care.

To guard against overturning:

- do not stop or start suddenly when going up or downhill;
- engage the drive slowly and always keep the machine in gear, especially when travelling downhill;
- machine speeds should be kept low on slopes and during tight turns;
- stay alert for humps and hollows and other hidden hazards;
- never mow across the face of the slope.
- use care when pulling loads or using heavy equipment:
- use only approved drawbar hitch points;
- limit loads to those you can safely control;
- do not turn sharply. Use care when reversing;
- use counterweight(s) or wheel weights whenever advised in the instructions manual.

- 6) Stop the blades before crossing surfaces other than grass.
- 7) Never use the machine with damaged guards, or without the safety protective devices in place.
- 8) Do not change the engine governor settings or overspeed the engine. Operating the engine at excessive speed can increase the risk of personal injury.
- 9) Before leaving the driving seat:
  - disengage the blades and lower the attachments;

- go into neutral and apply the parking brake;
  - stop the engine and remove the ignition key.
- 10) Disengage the blades, stop the engine and remove the ignition key:
- before clearing blockages or unclogging the collector channel;
  - before cleaning, checking or servicing the machine;
  - after striking a foreign object. Inspect the machine for damage and make repairs before restarting and operating the machine;
  - If the machine starts to vibrate abnormally (check for the causes immediately).
- 11) Disengage the blades for transport or whenever they are not in use.
- 12) Stop the engine and disengage the blades:
- before refueling;
  - before making height adjustments unless adjustment can be made from the operator's position.
- 13) Reduce the throttle during engine run-out. If the engine is provided with a shut-off
- 14) Cut off the fuel with the fuel valve when you have finished mowing.
- 15) Watch out for traffic when crossing or near roadways.
- 16) Never direct discharge of material towards bystanders nor allow anyone near the machine while in operation.

#### D) MAINTENANCE AND STORAGE

- 1) Keep all nuts, bolts and screws tight to be sure the equipment is in safe working condition.
- 2) Never store the equipment with petrol in the tank inside a building where fumes may reach an open flame or spark.
- 3) Allow the engine to cool before storing in any enclosure.
- 4) To reduce fire hazards, keep the engine, silencer, battery compartment and petrol storage area free of grass, leaves, or excessive grease.
- 5) Check the grass-catcher frequently for wear or deterioration.
- 6) Replace worn or damaged parts for safety purposes.
- 7) If the fuel tank has to be drained, this should be done outdoors.
- 8) On multi-bladed machines, remember that the rotation of one blade can cause other blades to rotate.
- 9) When the machine is to be parked, stored or left unattended, lower the cutting means unless a positive mechanical lock is used.

### 1.3 SAFETY LABELS

Your machine must be used with care. This is why labels with illustrations have been placed on the machine, to remind you of the main precautions to take during use. These labels are to be considered an integral part of the machine. Should a label come off or become illegible, contact your dealer to replace it. Their meaning is explained below.



**Warning:**

Read the instructions before operating this machine.



**Danger!**

**Dismemberment:**

Make sure that children stay clear of the machine at all time when engine is running.



**Warning:**

Disconnect the ignition key and read the instructions before carrying out any repair or maintenance work.



**Danger!**

**Risk of burns**

Wait for the engine to completely cool down before making any adjustments or servicing the engine itself.



**Warning:**

No step on the deck or discharge guard.



**Warning:** Do Not Step



**Danger:** Ejected Objects  
Always operate with the grass catcher or discharge guard in place



**Danger:** Risk of Injury  
Keep bystanders away  
Blades continue to rotate after switching off the engine or disengaging the blade.



**Warning:** Keep hands and feet away from blades



**Warning:**  
Never use a pressure washer on the transmission system.



**Danger:** Risk of overturning on steep slopes  
Do not use the machine on slopes with a longitudinal gradient greater than 15 degrees (27%).

Do not use the garden tractor on slopes with a lateral gradient greater than 10 degrees (18%).

#### 1.4 CAUTION WHEN TOWING

A kit for towing a small trailer is available on request. This accessory is to be fitted following the instructions provided, When using the towing kit. Do not exceed the recommended loads stated on the label and follow the safety instruction.

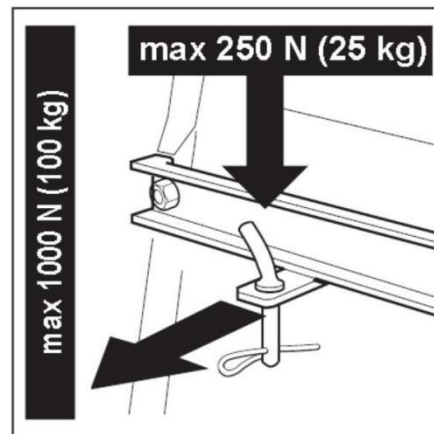



## 2. IDENTIFICATION OF THE MACHINE AND COMPONENTS

### 2.1 IDENTIFICATION OF THE MACHINE

The label located in the seat bracket has the essential data of each machine

1. Name and address of manufacturer.
2. Designation of the machine
3. Type of machine
4. Cutting width
5. Mass of machine
6. Nominal power of engine
7. Serial number
8. Year of manufacture
9. Acoustic power level according to directive 2000/14/CE
10. Conformity mark according to directive 2006/42/EC

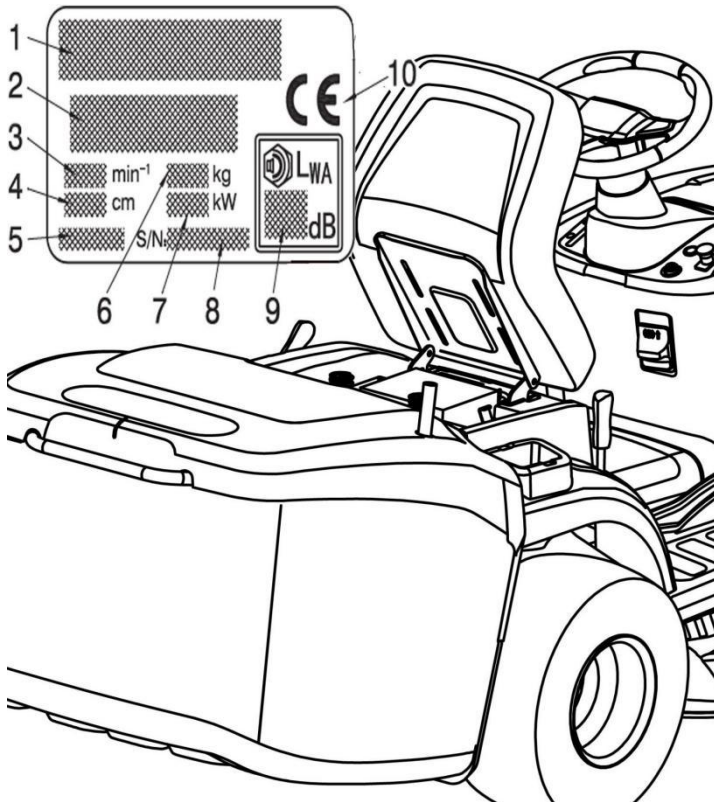

## 2.2 IDENTIFICATION OF MAIN COMPONENTS

The main components of the machine as following:

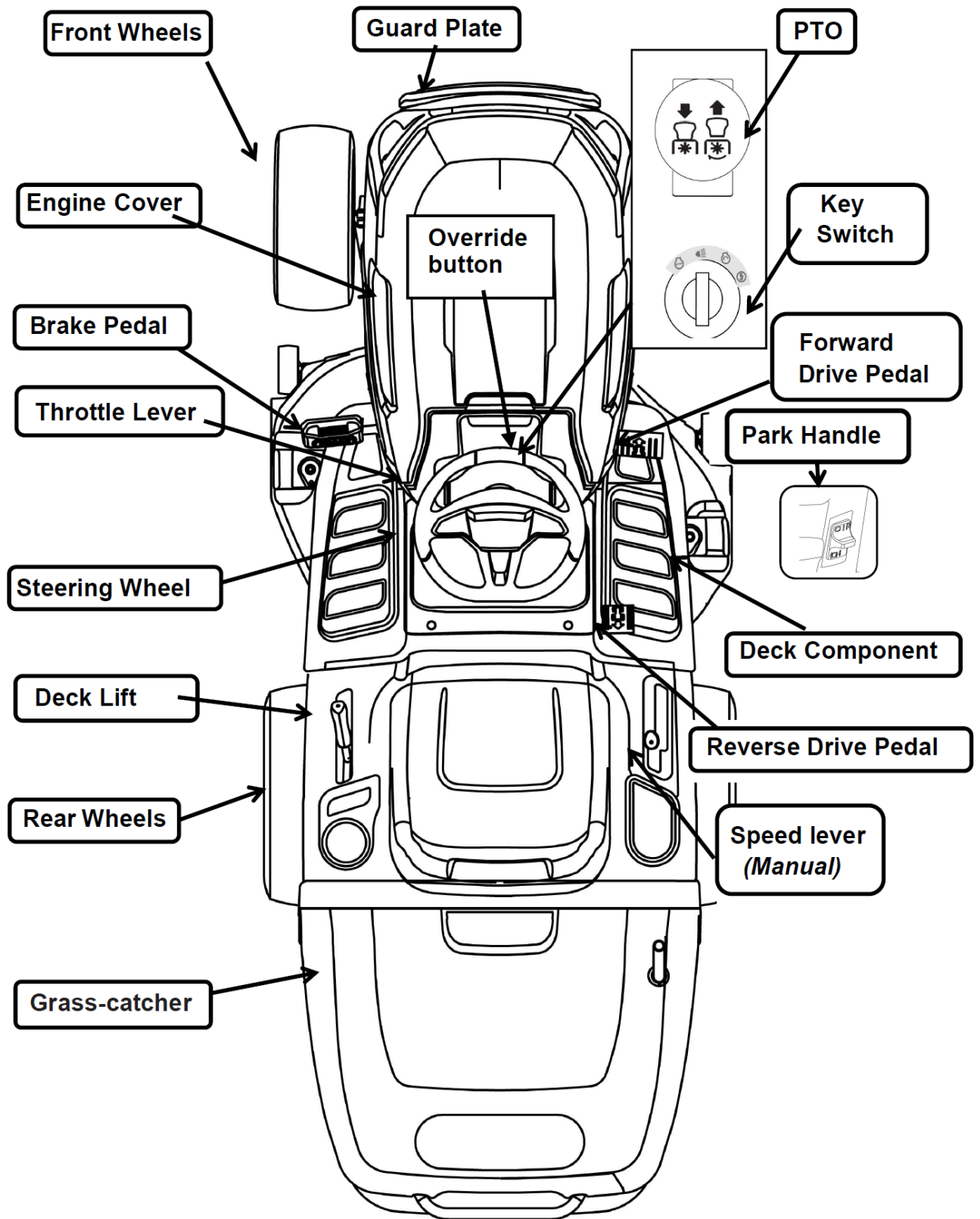

### 3. UNPACKING AND ASSEMBLY

For storage and transport purposes, some components of the machine are not installed in the factory and have to be assembled after unpacking.

Follow the instructions below:

**IMPORTANT** The machine is supplied without engine oil or fuel. Before starting the engine, fill with oil and fuel following the instructions given in the engine manual.

#### 3.1 UNPACKING

When unpacking the machine, take care to gather all individual parts and fittings, and do not damage the cutting deck when taking the machine off the pallet.

1. Machine body
2. Steering connect shaft
3. Towing bracket
4. Bumper
5. Bumper bracket L
6. Bumper bracket R
7. Steering wheel cover
8. Steering wheel
9. Splined hub
10. Steering shaft cover
11. Instruction manual
12. Nuts, bolts, washer, bushing and starter key
13. Tools
14. Seat
15. Grass-catcher component
16. Rear baffle plate component.

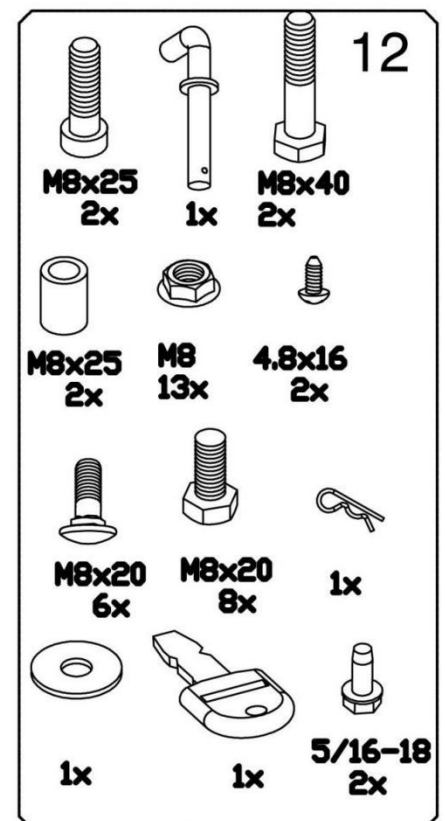
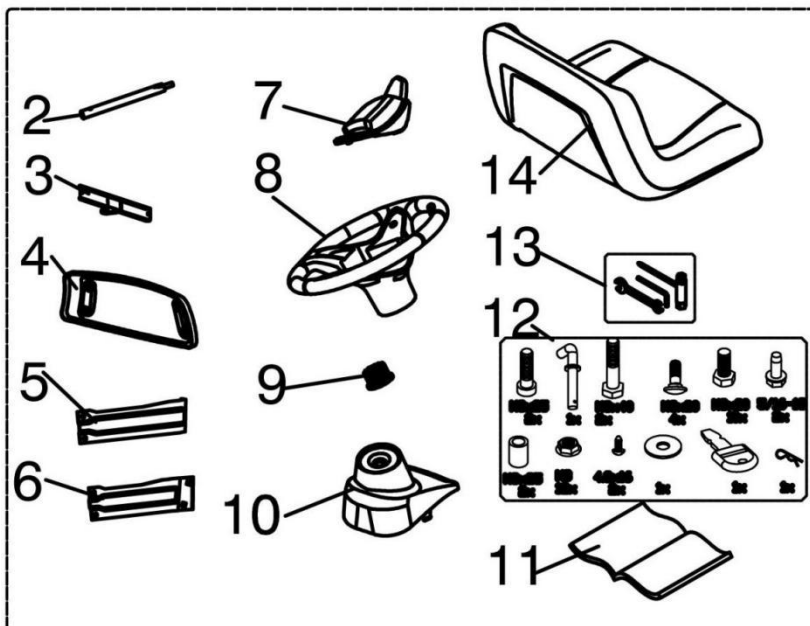
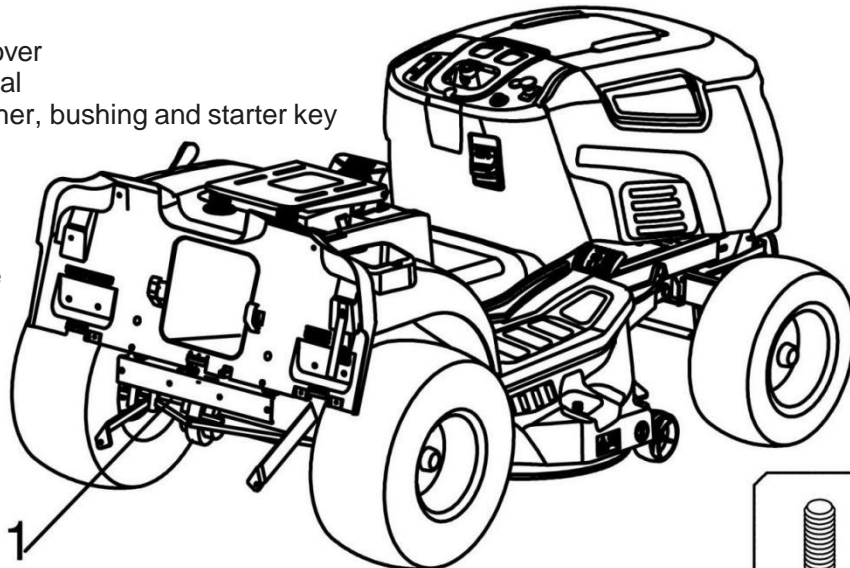

15. Grass-catcher component

- ① Cover;
- ② Top frame weldment;
- ③ Layer board;
- ④ Grass bag;
- ⑤ Front bracket;
- ⑥ Side stay pipe;
- ⑦ Overturn lever;
- ⑧ Nuts, bolts;
- ⑨ Swivel bracket (R);
- ⑩ Swivel bracket (L)

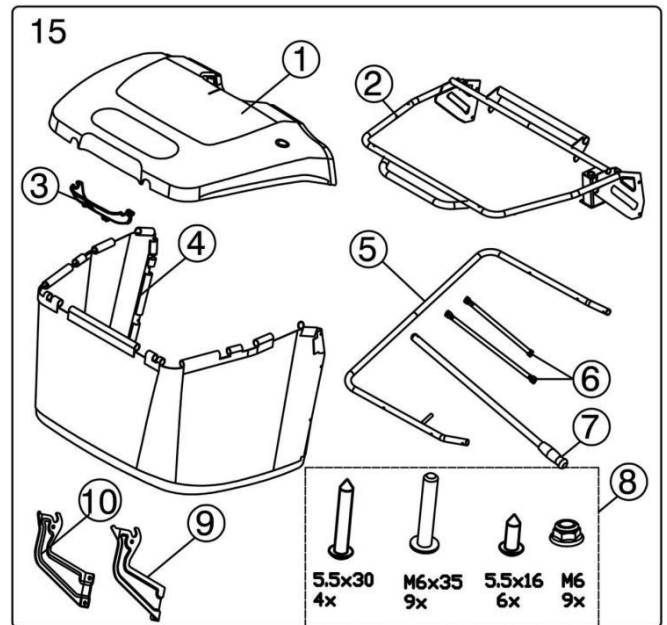

16. Rear baffle plate component.

**NOTE**

To prevent damage to the cutting deck, raise it to its maximum height and take utmost care when taking the machine off the pallet.

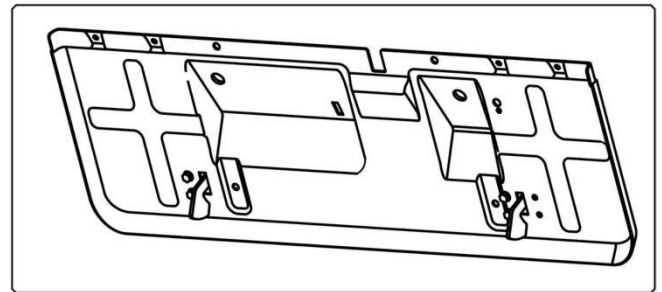

**3.2 FITTING THE STEERING WHEEL**

**Put the machine on a flat surface and straighten up the front wheels.**

a. Fit the shaft (1) onto the couplings and tightening the screw M8x25 (2). (Use the hex wrench 5 in accessories tools.)

b. Fit the steering shaft cover (3).

c. Inset the splined hub (4) to shaft (1), mounting steering wheel (5), spacer (6) and tightening nut M8 (7). (Use the open end wrench 13-15 in accessories tools.)

d. Inset the steering wheel cover (8) into steering wheel and tightening two screws (9). (Use the cross screwdriver in the accessories tools.)

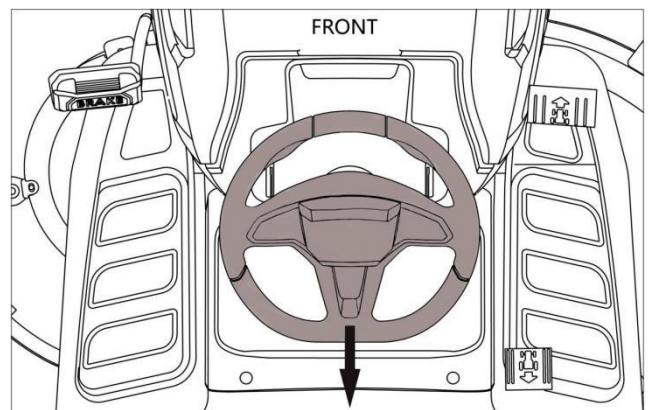
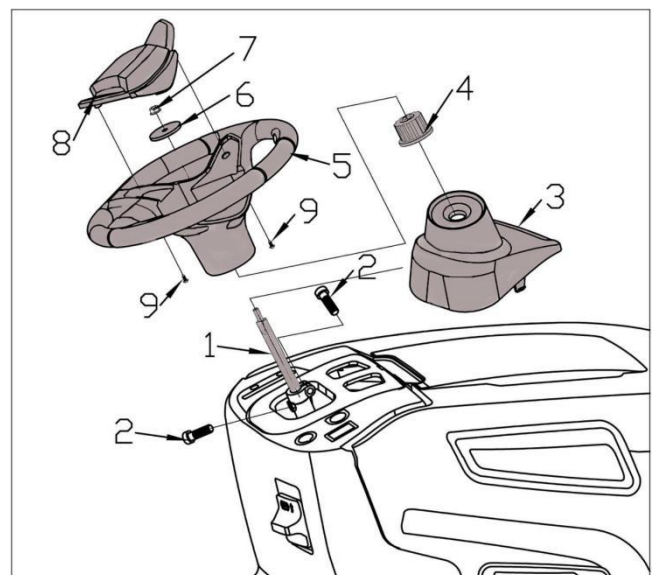

**NOTE**  
Pay attention to the direction when mounting the steering wheel .



## Only for LT86MRL (TTM86M) Manual Transmission

Put the machine on a flat surface and straighten up the front wheels.

- a. Fit the shaft (1) onto the couplings and tightening the screw M8x25 (2).  
(Use the hex wrench 5 in accessories tools.)
- b. Fit the steering shaft cover (3).
- c. Fit the steering wheel 4 onto the steering shaft ,  
insert screw (5) and tighten it by nut (6).

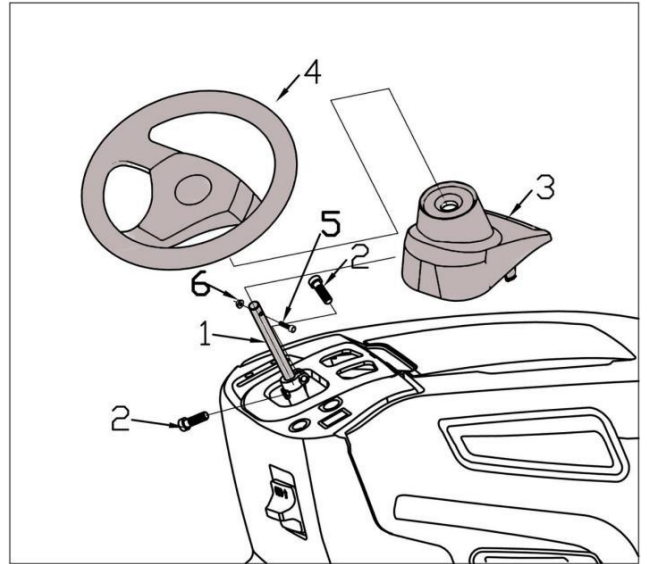

### 3.3 FITTING THE SEAT

Mount the seat on the plate using the screws. (Use the open end wrench 8-10 in accessories tools.)

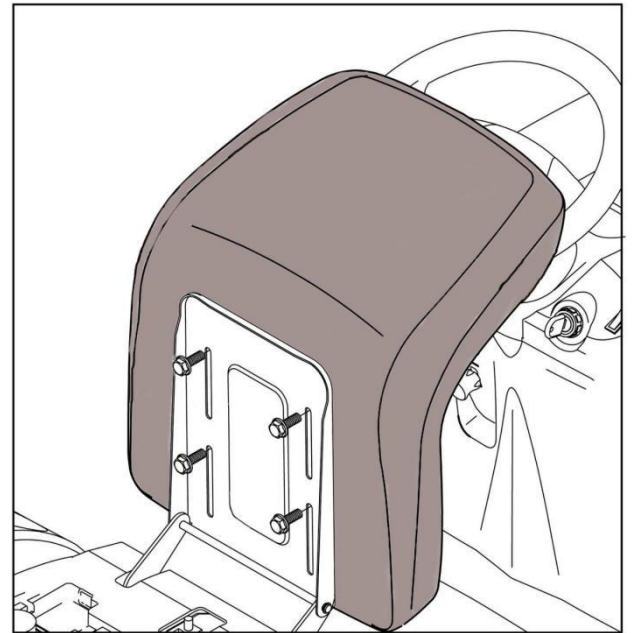

**For optional seat only (if applicable):**

- a. Fix the right armrest (1) on the seat with three M8 screws (2) using the Allen wrench in accessories tools, and fix the left armrest (3) on the seat in the same way;
- b. Snap the retaining ring (1) into the pin (2), use the pin to link the seat (3) to the bracket, and snap it into the retaining ring (4).

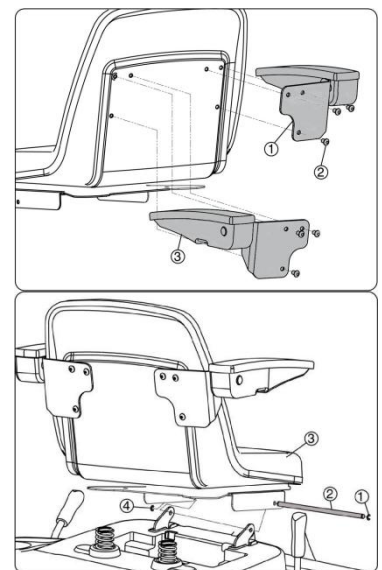



### 3.4 CONNECTING THE BATTERY



**The electrolytic fluid is a solution of sulphuric acid.  
Danger: Sulphuric acid is poisonous**



**Danger: Sulphuric acid is corrosive Sulphuric acid can cause blindness or severe burns.**



**Danger: Keep out of reach of children.**



**For EU countries only**

**Never place any electric power tools in your household refuse.**

To comply with European Directive 2012/19/EC concerning old electric and electronic equipment and its implementation in national laws, old electric power tools have to be separated from other waste and disposed of in an environment-friendly fashion, e.g. by taking to a recycling depot.



**Fit the battery in its housing.**

#### **IMPORTANT**

**Position the battery with the polarities (+) and (—)**

Connect the battery connectors to the machine connection leads and tighten the 2 screws. then cover the protective cap for the 2 wire is in place. (Use the open end wrench 8-10 and cross screwdriver in accessories tools)

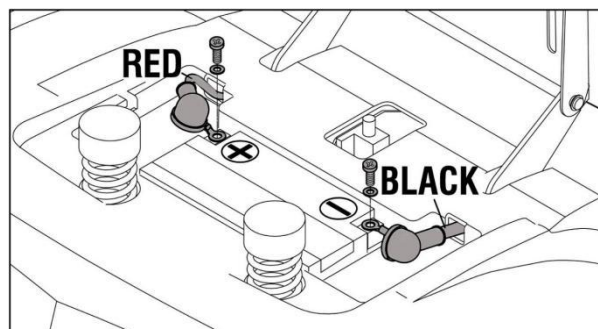

1) Secure the battery with the small rubber strap.

#### **NOTE**

The battery type:  
**12 V == 18Ah.**

The battery is fully charged before leaving the factory.  
If the battery is found to be insufficient, please use a 12V1A charger to charge the battery.

### 3.5 MOUNTING THE FRONT BUMPER

Mounting the bumper bracket L and bumper bracket R on the bumper, using 4 nuts and 4 screws. (Use the open end wrench 13-15 in accessories tools.)

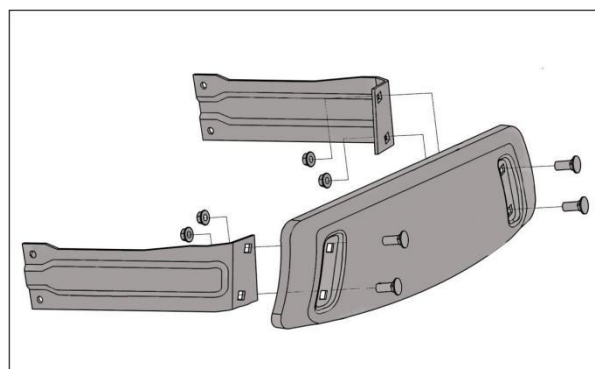

Mounting the front bumper on the bottom of the frame using the 4 nuts and 4 screws. (Use the open end wrench 13-15 in accessories tools.)

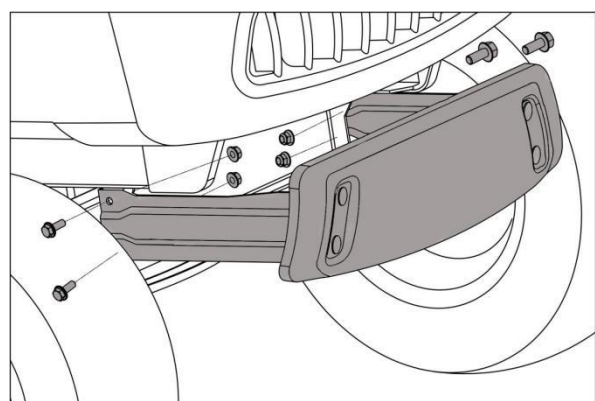

### 3.6 MOUNTING REAR Baffle PLATE COMPONENT

1. Mounting the Pull lever (a) crossing the hole (b);  
(see Figure m)
2. Mounting the rear baffle plate component on the frame using screws 1 (screw 5/16-18);
3. Mounting the rear baffle plate component on the bracket L&R using bolts 2 (M8-20);

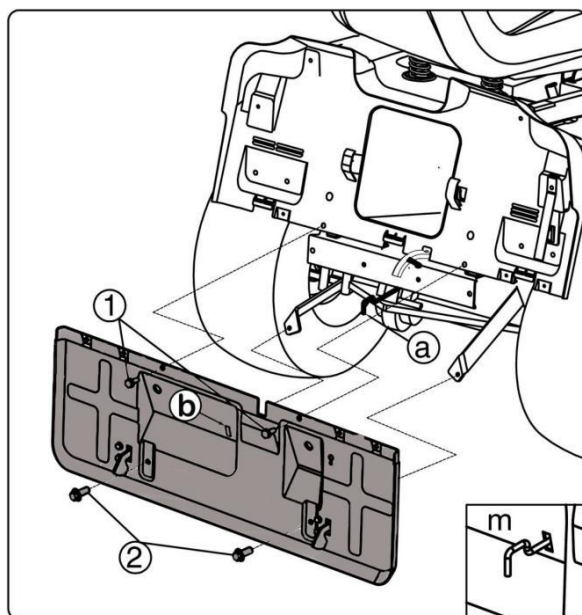

### 3.7 MOUNTING GRASS-CATCHER

1. Mounting the front bracket 2 on the Top frame 3 using four screws 1 (M6-35);
2. Mounting the side stay pipe 5 on the Top frame 3 and front bracket 2 using four screws 1 (M6-35);

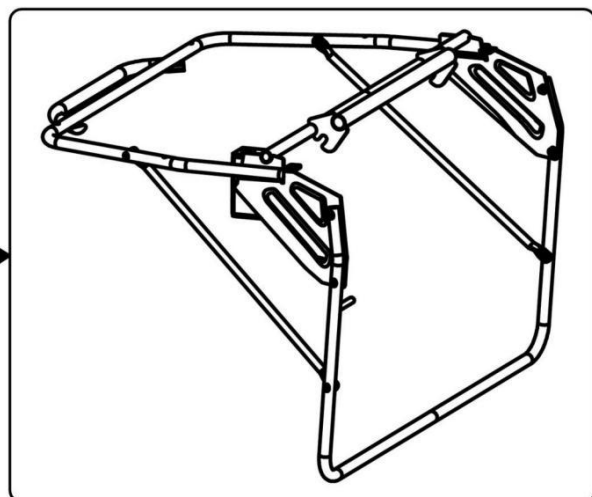
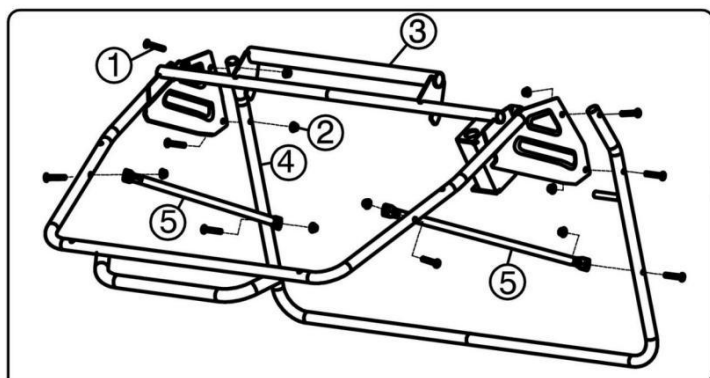

3. Mounting the grass bag on the frame component;
4. Mounting the cover (b) on the frame component using four screws (h) ST 5.5x35 and two screws (g) ST 5.5x16;
5. Put the overturn lever (a) into the grass-catcher cover board and insert the nut (e) and the bolt (d).

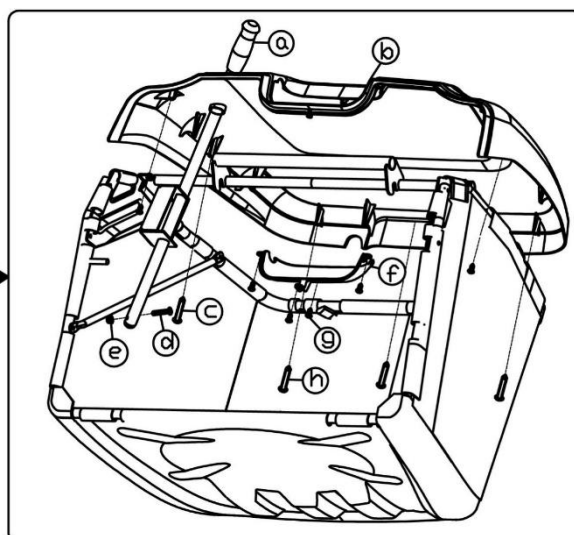
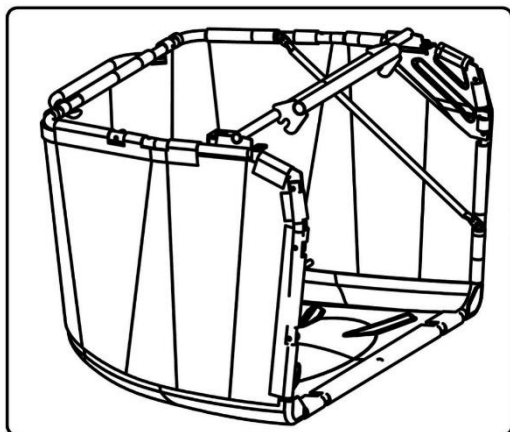

### Fitting the protection at the exit (grass-catcher)

**IMPORTANT**

- 1) Never use the machine without having fitted the exit guards.
- 2) Attach the grass-catcher to the brackets and centre it up with the rear plate, so that the two reference marks coincide.
- 3) Make sure that the lower pipe of the grass-catcher opening is attached to the pawl.

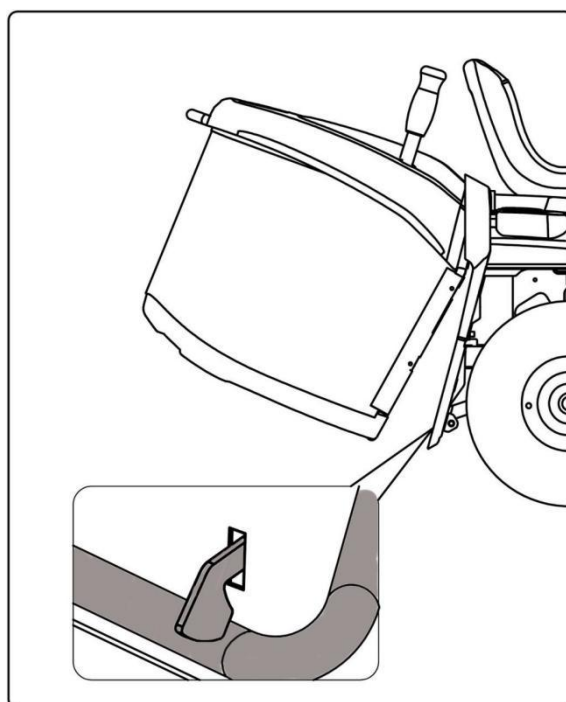

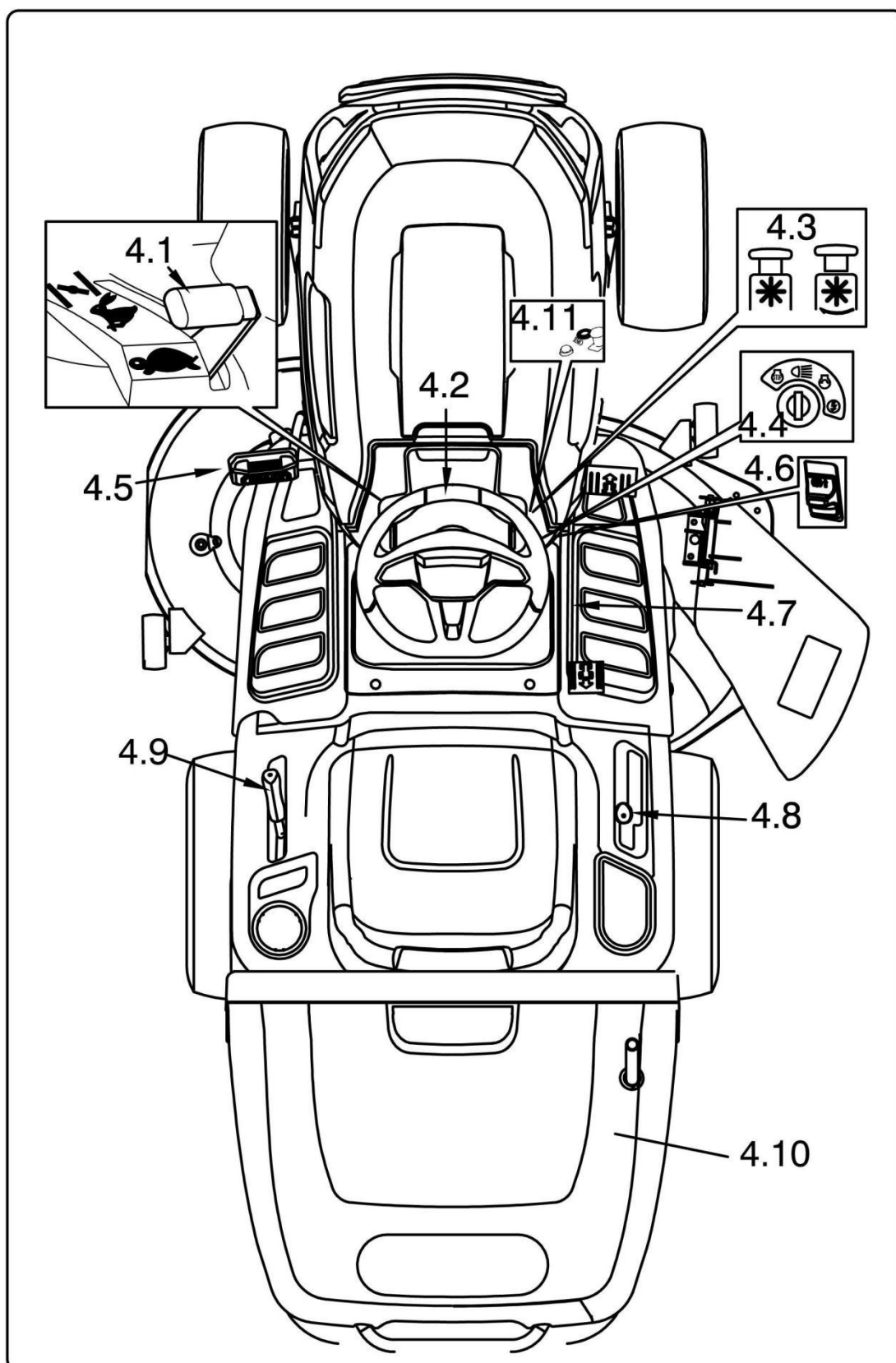

## 4.CONTROLS AND INSTRUMENTS



### 4.1 THROTTLE LEVER

This regulates the engine revs. The positions are indicated on a label showing the following symbols:

-  «CHOKE» cold starting
-  «SLOW» for minimum engine speed
-  «FAST» for maximum engine speed

- The «CHOKE» position enriches the mixture so must only be used if necessary when starting from cold.
- When moving from one area to another, put the lever in a position between «SLOW» and «FAST».
- When cutting, shift into «FAST»

#### 4.2 STEERING WHEEL

Turns the front wheels

#### 4.3 BLADE START/STOP KNOB

The blade start/stop knob is located on the RH console in front of the key switch. The blade start/stop knob operates the electric clutch. Pull the knob upward to engage the blades, or push the knob downward to disengage the blades.

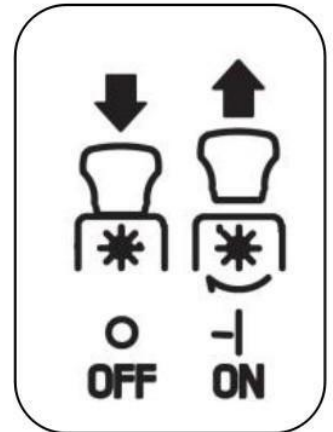

#### 4.4 KEY IGNITION SWITCH

This key operated control has four positions:



«OFF» everything is switched off.



«ON» activates all parts



«START» connects the starter Motor.

If you release the key on «START», it will automatically return to «ON».



This selection sends power to the head lights when the switch is in this position.

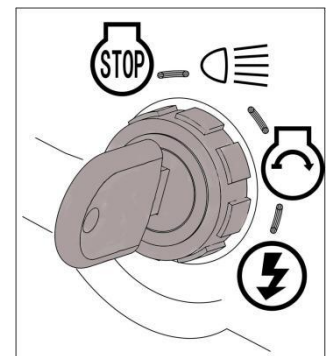

#### 4.5 Brake Pedal

The brake pedal is located on the left front side of the board. The brake pedal can be used for sudden stops or setting the parking brake.

##### NOTE

When the machine is moving, keep your foot off the pedal.



#### 4.6 PARKING BRAKE LEVER

With the machine stopped:

- 1) Keep the brake pedal pressed;
- 2) Lift the parking brake lever and keep lifted;
- 3) Release the brake pedal.

This way, the rear wheels remain braked. To release



the parking brake, fully press the brake pedal (the parking brake lever is automatically released and returns to down position).

##### NOTE

The engine can only be started at the parking position.

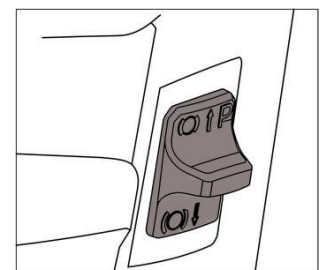



## 4.7 DRIVE ENGAGEMENT PADAL

(for hydrostatic transmission model)

This pedal engages drive in the wheels as well as modulating the machine's forward and reverse speeds.

To engage forward drive, press it towards «F» with your toecap.

As you increase the pressure on the pedal, the speed of the machine increases.

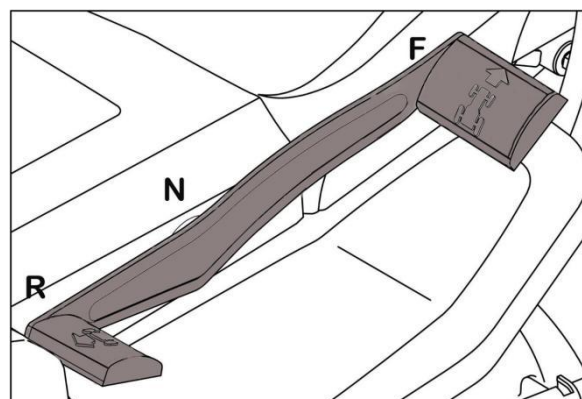

Reverse is engaged by pressing the pedal with the heel towards «R».

The pedal automatically goes into neutral «N» when released.



**WARNING!** Reverse must only be engaged when the machine is stopped.

**NOTE**

Release the parking brake whilst engaging the drive

## 4.8 SPEED CHANGE LEVER

(for manual gear model)

This lever has seven positions for the 5 forward speeds, the neutral position «N», and reverse «R».

When shifting the speed change lever, press the brake pedal to disengage the drive belt and shift the lever as shown on the label.

Never directly shift the lever from forward to reverse or from reverse to forward before the machine coming to stop completely.

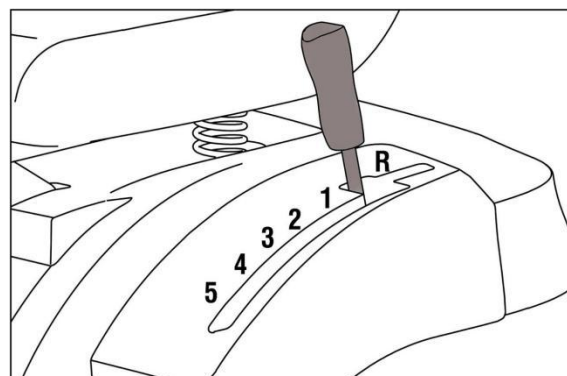

**WARNING!** Only shift into reverse when the machine has stopped moving.

## 4.9 CUTTING HEIGHT ADJUSTMENT LEVER



Lifts or lowers the blade deck and thereby adjusts the grass cutting height. There are seven positions for this lever (shown as «1» to «7» on the label), which correspond to various heights between 30 and 90 mm

## 4.10 GRASS-CATCHER

This overturn lever tips and empties the grass-catcher. This means less work for the operator.

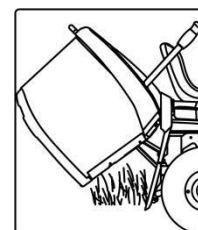

## 4.11 Reverse Mode Operation Button (RMO)

The reverse mode operation knob is located on the RH console to the left of the blade start/stop knob. The blades will stop when traveling in reverse. To keep the blades rotating when traveling in reverse, press the button RMO.

**NOTE: Mowing in reverse is not recommended. Always ensure it is safe to mow before proceeding.**

## 5 HOW TO USE THE MACHINE

### 5.1 SAFETY RECOMMENDATIONS

#### **▲ DANGER!**

The machine must only be used for the purpose for which it was designed (cutting grass). Do not tamper with or remove the safety devices fitted on the machine.

#### **REMEMBER THAT THE USER IS ALWAYS RESPONSIBLE FOR DAMAGE AND INJURY TO OTHERS.**

Before using the machine:

- read the general safety regulations, paying particular attention to driving and cutting on slopes;
- carefully read the instructions for use, make sure you are familiar with the controls and know how to stop the blades and the engine quickly;
- never put your hands or feet next to or beneath the rotating parts and always keep away from the exit.

Do not use the machine when unwell or under the influence of medicine or any other substances that can reduce your reflex actions and your ability to concentrate. It is the user's responsibility to assess the potential risk of the area where work is to be carried out, and to take all the necessary precautions to ensure their own safety and that of others, particularly on slopes or rough, slippery and unstable ground.

Do not leave the machine on high grass with the engine running to avoid the risk of starting a fire. Ensure grass cuttings are cleared from the tractor to avoid a potential fire.

#### **▲ WARNING!**

Do not use the machine on slopes with longitudinal gradients of more than 15°(27%); do not use the machine on slopes with lateral gradients above 10°(18%). If the machine is likely to be used mostly on sloping ground fit counterweights beneath the cross-member of the front wheels. These improve stability at the front and reduce the chances of tipping over.

#### **IMPORTANT**

All the references relating to the positions of controls are described in chapter 4.

### 5.2 THE SAFETY DEVICES OPERATION

The safety devices work in two ways:

- they prevent the engine from starting if all the safety requirements have not been met;
- they stop the engine even if just one of the safety requirements is not met.

a) To start the engine, it is necessary that:

- the blades are not engaged;
- the parking brake is engaged and the transmission is disengaged;
- the operator sits on the seat;

b) The engine stops when:

- the operator leaves his seat while mowing or driving;

### 5.3 DIRECTIONS BEFORE STARTING WORK

Before starting to mow, it is necessary to carry out several checks and operations to ensure you can work efficiently and in maximum safety.

#### 5.3.1 Seat adjustment

To change the seat position, loosen the four fixing bolts and slide it along the slots.

Once you have found the right position, tighten the four screws.

#### Where the optional seat is fitted

To adjust the position of the seat, pull up and hold the seat adjustment lever. Slide the seat forward or rearward to the desired position; then release the adjustment lever. Make sure seat is locked into position before operating the tractor.

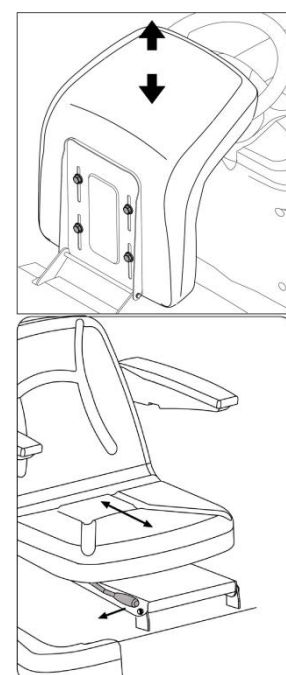

### 5.3.2 Tyre pressure

Having the right tyre pressure is the main condition for ensuring that the cutting deck is horizontal and mows evenly.

Unscrew the valve caps and connect a compressed air line with a gauge to the valves.

The pressures are:

FRONT 1.0 bar (15 x 6.0-6)

REAR 1.2 bar (18 x 8.5-8)

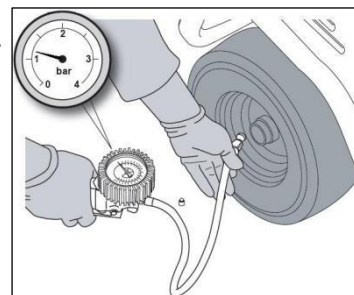

### 5.3.3 Checking the fuel and oil

#### NOTE

The engine manual indicates what type of oil and fuel you can use. With the engine off, check the oil level. According to the instructions in the engine manual, this must be between the MIN and MAX marks on the dipstick. Refuel using a funnel, but do not completely fill the tank. The tank's capacity is about 7.5 litres.

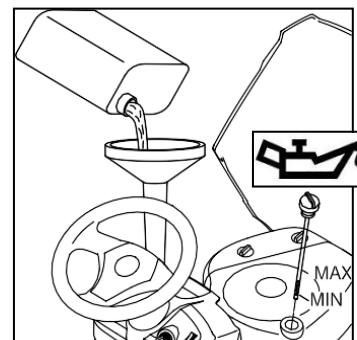

#### ⚠ DANGER!

Refueling should be carried out in an open or well ventilated area with the engine off. Always remember that petrol fumes are inflammable.

**DO NOT USE A NAKED FLAME TO LOOK INSIDE THE TANK AND DO NOT SMOKE WHEN REFUELLING**

#### IMPORTANT

Do not drip petrol onto the plastic parts to avoid damaging them. In the event of accidental spills or leaks, rinse immediately with water. The warranty does not cover for damage to plastic parts of the bodywork or the engine caused by petrol.

### 5.3.4 Checking machine safety and efficiency

- Check that the safety devices function as described.
- Check that the brake is in perfect working order.
- Do not start mowing if the blades vibrate or if you are unsure whether they are sharp enough. Always remember that:
  - A badly sharpened blade pulls at the grass and causes the lawn to turn yellow.
  - A loose blade causes unwanted vibrations and can be dangerous.

#### ⚠ WARNING!

Do not use the machine if you are unsure whether it is working safely or efficiently. If in doubt, contact your Dealer immediately to make the necessary checks and repairs.

### 5.3.5 Hydrostatic transmission disengagement lever

This lever has two positions as shown on the label:

«A» = Transmission engaged: for all uses, when moving and during cutting;

«B» = Transmission disengaged: this makes it much easier to move the machine by hand, with the engine

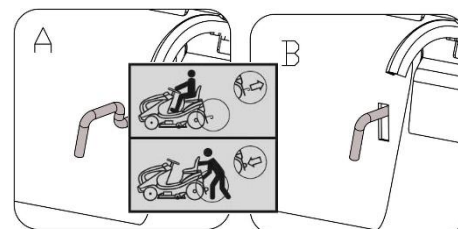

## 5.4 USING THE MACHINE

### 5.4.1 Starting



**DANGER!** The engine must be started in an open or well ventilated area!  
**ALWAYS REMEMBER THAT EXHAUST GASES ARE TOXIC!**

To start the engine:

- open the fuel stopcock(to "I"); close the engine cover ;
- lift the cutting deck raised as high as possible.
- disengage the blades ;
- shift the gear lever to neutral;
- operate the parking brake ;
- when starting from cold, move the throttle to the «CHOKE» position shown on the label;
- if the engine is already warm, position the lever between «SLOW» and «FAST»;
- put in the ignition key and turn to «ON» to make electrical contact, then turn to «START» to start the engine;
- release the key once the engine has started. When the engine has started, move the throttle to «SLOW».

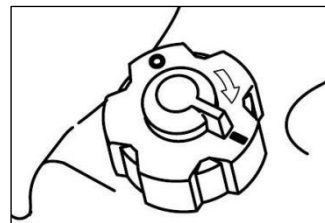

**IMPORTANT** The choke must be opened as soon as the engine is running smoothly. Using it when the engine is already warm can foul the spark plugs and cause the engine to run erratically.



**NOTE** If there are engine starting issues - do not continuously turn the engine over. This will run the battery flat and flood the engine. Instead turn the key to «OFF», wait for a few seconds and then repeat the operation. If the malfunction persists, refer to the engine manual.



**IMPORTANT** Always bear in mind that the safety devices prevent the engine from starting if safety requirements have not been met. In these cases, once the situation has been corrected, the key must first be turned back to «OFF» before the engine can be restarted.

### 5.4.2 Starting and moving without mowing



**WARNING!** This machine has not been approved for use on public roads. It has to be used (as indicated by the highway code) in private areas closed to traffic.

When moving the machine, the blades must be disengaged and the cutting deck raised as high as possible. (position«7»)

Position the throttle between «SLOW» and «FAST» and the gear lever in first gear.

Keep the brake/clutch pedal pressed down and release the parking brake slowly release the brake/clutch pedal to start forward movement of the machine.



**WARNING!** The brake pedal has to be released gradually as a sudden engagement may cause the vehicle to tip over and the diver to lose control.

Gradually reach the desired speed using the throttle and gear lever. To change gear, the clutch must always be used by pushing the brake pedal.

### 5.4.3 Braking

First slows down the machine by reducing the engine speed, and then push the pedal right down to lower the speed even more until the machine stops.

### 5.4.4 Reverse



**IMPORTANT** Reverse must be engaged only when the machine has stopped. Press the brake pedal until the machine stops and then go into reverse by shifting the lever sideways and into position «R». (for manual gear model)

Gradually release the brake pedal to engage the clutch and then begin moving in reverse. When the machine is stopped, start the reverse movement by pressing the drive engagement pedal in the «R» direction. **(for hydro transmission model)**

#### 5.4.5 Grass cutting

To start cutting:

- move the throttle to «FAST»;
- raise the cutting deck as high as possible;
- engage the blades;
- start moving forwards on the grass very slowly and with utmost caution, as already described;
- regulate the cutting height and speed considering the conditions of the lawn. (The height, density and dampness of the grass).

**▲ WARNING!** When cutting on sloping ground, reduce your speed to ensure safe operation.

Whatever the conditions, always reduce the speed if you notice a drop in engine speed. – if you travel too fast compared to the amount of grass being cut, you will not be able to mow the grass as well.

Disengage the blades and raise the cutting deck as high as possible whenever you need to get past an obstacle.

**IMPORTANT** This tractor will stop the blades when reverse is selected.

**Press the override button (left of the steering wheel) to keep the blades rotating. Apply additional attention when mowing in reverse, ensure it is safe to do so.**

#### **NOTE** 5.4.6 Emptying the grass-catcher

This operation can only be done with the blades disengaged, otherwise the engine stops.

Do not let the grass-catcher become too full as this may block the collector channel. When the grass-catcher is full you will hear a sound warning. At this point:

- disengage the blades and the sound will stop;
- lower the engine speed;
- stop moving forward;
- engage the parking brake on slopes;
- pull out the overturn lever and tip up the grass-catcher to empty it;
- close the grass-catcher so that it hooks onto the pawl.

**NOTE** At times the audible warning may be heard when engaging the blade, even when the grass-catcher has been emptied. This is due to grass-cuttings left on the sensor of the micro-switch.

To stop the signal, disengage the blades and then immediately engage them again. If the warning sound continues, stop the engine, take off the grass-catcher and remove any accumulated grass-cuttings from the sensor.



#### 5.4.7 Unblocking the collector channel

Cutting very tall or wet grass, particularly at excessively high speed, can clog up the collector channel. If this happens proceed as follows:

- stop moving forward, disengage the blades and stop the engine;
- remove the grass catcher;
- remove the grass cuttings; you can reach them from the exit of the collector channel.

**▲ WARNING!**

**STOP THE ENGINE BEFORE CLEARING THE GRASS FROM THE CHUTE.**



#### 5.4.8 End of mowing

When you have finished mowing, disengage the blades, lower the engine speed and ride the machine with the cutting deck raised as high as possible.

#### 5.4.9 End of work

Stop the machine, move the throttle to «SLOW» and turn off the engine by turning the key to «OFF». When the engine has stopped, close the fuel stopcock.

**▲ WARNING!** To avoid backfire, position the throttle on «SLOW» for 20 seconds before stopping the engine

**▲ WARNING!** Always take out the ignition key before leaving the machine unattended

**IMPORTANT** Never leave the key in the «ON» position. The battery will run flat.

#### 5.4.10 Cleaning the machine

After use, clean the outside of the machine, empty the grass-catcher or discharge guard, and shake it to remove grass and other debris. Clean the plastic parts of the body with a damp sponge using water and detergent, taking care not to wet the engine, the electrical parts or the electronic circuit board located under the dashboard.

**IMPORTANT** Never use hose nozzles or harsh detergents to clean the bodywork or the engine!

When washing the inside of the cutting deck and the collector channel, the machine must be on firm ground with:

- the grass-catcher or discharge guard fitted;
- the operator seated;
- the engine running;
- the transmission in neutral;
- the blades engaged.

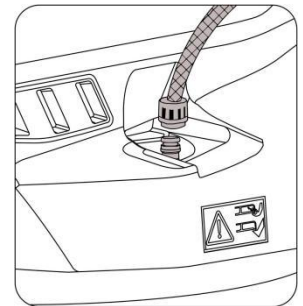

Connect a water hose to each of the pipe fittings one at a time and run water through each one for a few minutes, with the blades moving. When washing, the cutting deck should be lowered right down. Take off the grass-catcher, empty and rinse it, and then put it in a position where it can dry quickly.

#### 5.4.11 Storage and inactivity for long periods

If you intend not to use the machine for a long period (more than 1 month), disconnect the battery cables and follow the instructions in the engine manual.

Empty the fuel tank by disconnecting the tube situated at the inlet of the fuel filter and follow the instructions in the engine manual. Ensure there is no potential for ignition sparks before proceeding. Proceed with caution.

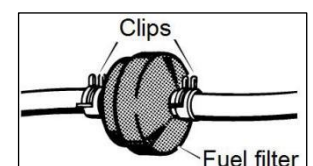

**▲ WARNING!** REMOVE GRASS AND DEBRIS FROM AROUND THE ENGINE & EXHAUST

This prevents the engine overheating and removes a potential hazard of dried debris catching fire. Put the machine away in a dry, sheltered place and preferably covered with a cloth.

**IMPORTANT** The battery must be kept in a cool and dry place. Before a long storage period (more than 1 month), always charge the battery, and then recharge before using again. The next time the machine is used, check that there are no fuel leaks from the tubes, fuel stopcock or carburetor.

#### 5.4.12 Circuit protection device

The electronic circuit board has a self-resetting protector which breaks the circuit if there is a fault in the electrical system. It results in the stopping of the engine and the switching off of the lamp. The circuit automatically resets after a few seconds, but the cause of the fault should be identified and corrected to avoid reactivating the protection device.

**IMPORTANT** To avoid activating the protection device:

- do not invert the leads on the battery terminals;
- do not use the machine without its battery or damage may be caused to the charging regulator
- do not cause short circuits.

#### 5.4.13 Summary of main steps to follow when using the machine

To...	You must...
Start the engine	Open the fuel stopcock, ensure that all the conditions allowing starting are met, and then turn the key
Go forward	push the pedal right down, engage the gear and then gradually release the pedal.
Brake or stop	Reduce the engine speed and press the brake pedal.
Reverse	Stop the machine; put into neutral, push the pedal right down, engage reverse, and then gradually release the pedal.
Cut the grass	Fit the discharge guard; apply the throttle; engage the blades; adjust the cutting height, push the pedal right down, engage the gear and then gradually release the pedal.
Unblock the collector channel	Stop moving forwards, disengage the blades and turn off the engine. Open the discharge guard and clean the collector channel..
Finish mowing	Disengage the blades and reduce the engine speed.
Stop the engine	Reduce the engine speed, wait a few seconds, turn the key and close the fuel stopcock.
Store the machine ( 5.4.9)	Engage the parking brake, remove the key and, if necessary, wash the machine, the inside of the cutting deck, the collector channel and the grass-catcher

#### 5.5 USING ON SLOPING GROUND

Only mow on slopes with gradients up to the maximum already mentioned. Lawns on a slope have to be mowed moving up and down and never across them. When changing direction, take great care that the wheels facing up the slope do not hit any obstacles (such as stones, branches, roots, etc.) that may cause the machine to slide sideways, tip over or make you lose control



**▲ DANGER!** **REDUCE SPEED BEFORE ANY CHANGE OF DIRECTION ON SLOPES**

Always apply the parking brake before leaving the machine at a standstill and unattended.

**▲ WARNING!** **Start moving forwards very carefully on sloping ground to prevent the risk of tipping over. Reduce the forward speed before going on a slope, particularly downhill.**

**▲ DANGER!** **NEVER USE REVERSE TO REDUCE SPEED GOING DOWNHILL: this could cause you to lose control of the vehicle, especially on slippery ground.**

**▲ DANGER!** **Never ride the machine on slopes in neutral gear or with the clutch out ! Always engage a low gear before leaving the machine stopped and unattended.**

## SLOPE GAUGE GUIDE

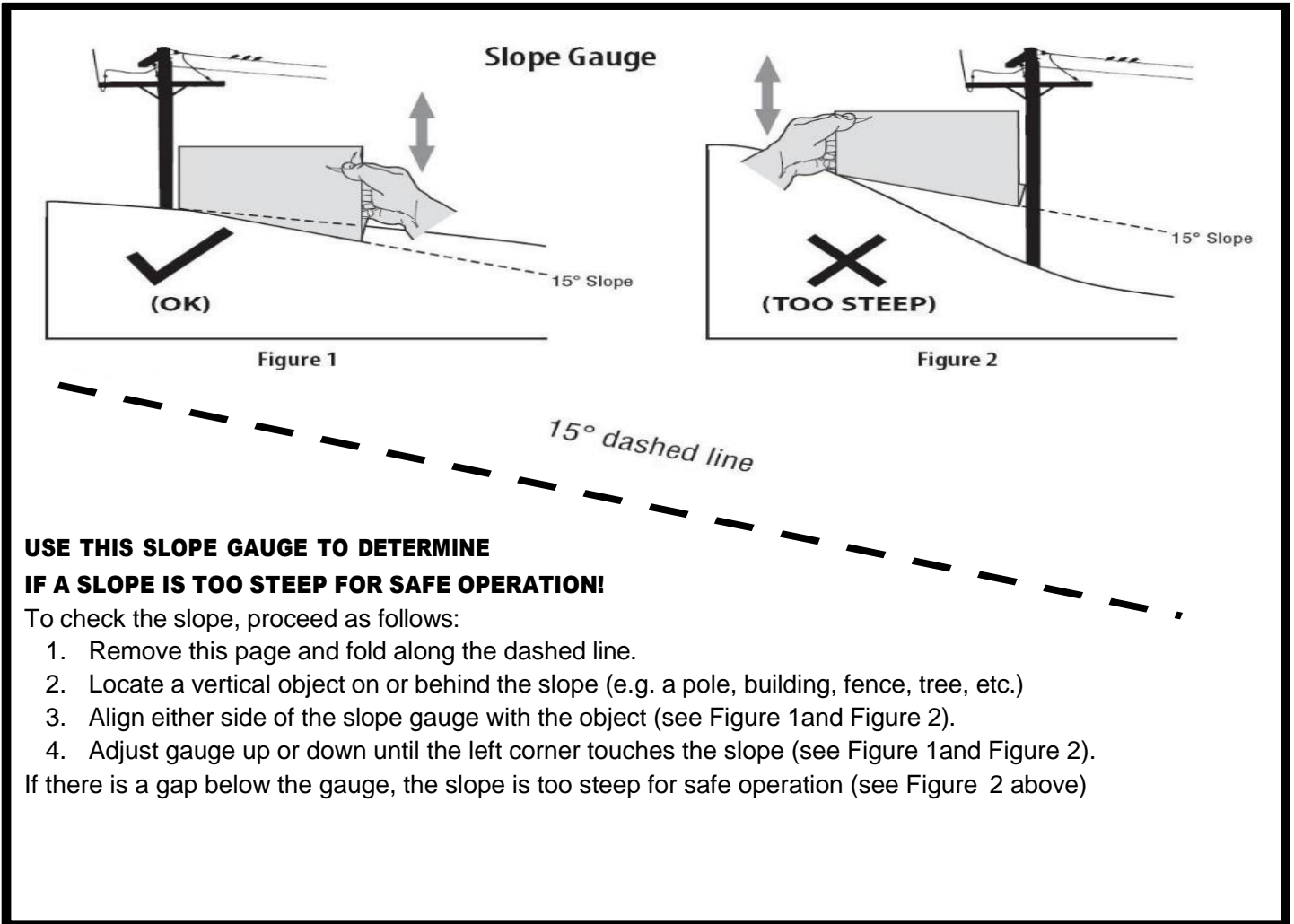

### USE THIS SLOPE GAUGE TO DETERMINE IF A SLOPE IS TOO STEEP FOR SAFE OPERATION!

To check the slope, proceed as follows:

1. Remove this page and fold along the dashed line.
2. Locate a vertical object on or behind the slope (e.g. a pole, building, fence, tree, etc.)
3. Align either side of the slope gauge with the object (see Figure 1 and Figure 2).
4. Adjust gauge up or down until the left corner touches the slope (see Figure 1 and Figure 2).

If there is a gap below the gauge, the slope is too steep for safe operation (see Figure 2 above)

### **⚠ DANGER!**

Slopes are a major factor related to tip-over and accidents, which can result injury or death. Do not operate machine on slope in excess of 15 degrees, All slopes require extra caution. Always mow across the face of slopes, never up and down slopes.

## 5.6 TRANSPORTING

### **⚠ WARNING!**

If the machine is transported on a truck or trailer, use suitable equipment for lifting and enough people for the weight involved and the type of lifting system used.

The machine must never be lifted by rope and tackle. During transport, close the fuel stopcock, lower the cutting deck, apply the parking brake and fasten the machine securely with ropes or chains to the hauling device.

## 5.7 LAWN MAINTENANCE

1. To keep a lawn green, soft and attractive, it should be cut regularly without damaging the grass. A lawn can be composed of different types of grass. If the lawn is cut frequently, grass and roots grow more vigorously, forming a solid grassy bed. If the lawn is cut less frequently, higher grass and weeds start growing (plus daisies and clovers, etc.).

2. It is always better to cut the grass when dry.

3. The blades must be in good condition and well sharpened so that the grass is cut straight without a ragged edge that leads to yellowing at the ends.
4. The engine must run at full speed, both to ensure a sharp cut of the grass and to get the necessary thrust to push the cuttings through the collector channel.
5. The frequency of mowing should be in relation to the rate of growth of the grass. The grass should not be left to grow too much between one cut and the next.
6. During hot and dry periods, the grass should be cut a little higher to prevent the ground from drying out.
7. The best height of the grass on a well-kept lawn is approx. 4-5 cm. With one cut, you do not need to remove more than a third of the total height. If the grass is very tall, it should be cut twice in a twenty-four hour period – the first time with the blades at maximum height, possibly reducing the cutting width, and the second cut at the desired height.
8. When you mow large areas, start by turning to the right so that the cut grass will discharge away from shrubs, fences, drive-ways, etc. After one or two rounds, mow in the opposite direction making left turns until finished.
9. The appearance of the lawn will improve if you alternate cutting in both directions.
10. If the collector system tends to get blocked with grass, you should reduce the forward speed as it may be too high for the condition of the grass. If the problem persists, the probable causes are either badly sharpened blades or deformed blade wings.
11. Be very careful when mowing near bushes or kerbs as these could distort the horizontal position of the cutting deck and damage its edge as well as the blades.

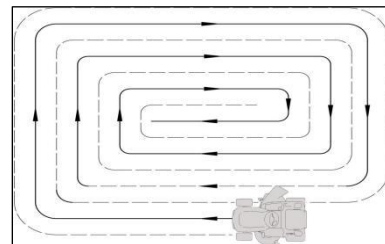

## 6 MAINTENANCE

### 6.1 SAFETY RECOMMENDATIONS

**⚠ WARNING!** Before cleaning or doing maintenance work, take out the ignition key and read the relevant instructions. Wear appropriate clothing and work gloves whenever your hands are at risk.

**⚠ WARNING!** Never use the machine with worn or damaged parts. Faulty or worn-out parts must always be replaced and not repaired. Only use original spare parts: Parts that are not of the same quality can damage the equipment and affect your safety and that of others

**IMPORTANT** Never dispose of used oil, fuel, batteries or other pollutants in unauthorised places!

## 6.2 SCHEDULED MAINTENANCE

### 1. MACHINE

1.1 Check oil engine	Before each use								
1.2 Tyres pressure check	Before each use								
1.3 Safety checks & Controls	Before each use								
1.4 Checking damage on products	Before each use								
1.5 Cleaning global product	After each use								
1.7 Check of fastening and sharpness blades	Each 25 hours								
1.8 Transmission belt check	Each 25 hours								
1.9 Blade blet check	Each 25 hours								
1.10 Bolt and screw check	Each 25 hours								
1.11 General Lubrication	Each 25 hours								
1.12 Blade replacement Each	Each 100 hours								
1.13 Global maintenance review made by Authorized Dealer or Service Centre	Every year								

### 2. ENGINE

2.1: First Oil change	After 20 hours								
2.2 Oil engine change	Each 50 hours								
2.3 Air filter cleaning	Each 50 hours								
2.4 Check and adjust Spark Plug	Each 100 hours								
2.5 Fuel tank and fuel filters cleaning	Each 100 hours								
2.6 Air filter replacement	Every year								
2.7 Spark plug replacement	Every year								

#### **IMPORTANT**

The above working hours are a guide. Service the tractor more frequently in dusty conditions or extreme heat. Always refer to the engine manual for further details and instructions on service intervals.

At the first signs of wear, contact your Cobra dealer replace worn parts. General lubrication of all joints should be carried out annually and when ever the machine is to be left unused for a long period.

#### **▲ WARNING!**

A qualified technician should complete all required service work. Please refer to your local Cobra dealer for service and warranty repairs.

For the following situations, please contact your dealer: blade vibrates, blade tears the grass, blade engagement is problematic, tractor does not brake correctly, movement is erratic.

If the cut is uneven, the alignment of the cutting deck will be necessary. A service dealer will be able to complete this task.

### 6.2.1 Engine

#### **IMPORTANT**

Follow all the instructions in the engine manual.

To empty the engine oil, unscrew the oil plug. When refitting the plug, make sure the seal is positioned correctly.



## 6.2.2 Battery

The battery must be carefully maintained to ensure long life. The machine battery must always be charged:

- before using the machine for the first time after purchase;
- before leaving the machine unused for a long period;
- before starting up the machine after a long period of disuse.

Carefully read and observe the battery recharging instructions in the booklet provided with the battery. Failure to follow the instructions or in charging the battery could permanently damage the battery cells.

A flat battery **must** be recharged as soon as possible.

### IMPORTANT

Recharging must be done using a battery charger at **constant voltage**. Other recharging systems can irreversibly damage the battery.

## 6.3 CHECKS AND ADJUSTMENTS

The cutting deck should be properly set to obtain a good cut.

### NOTE

To achieve good cutting results, ensure the cutting deck is adjusted correctly. The front of the deck should be 5-6mm lower than the rear.

- Put the machine onto a flat level surface and check the tyre pressures;
- Put 30 mm blocks under the front edge of the deck and 35 mm blocks under the rear edge, and then put the lifting lever into position «2» ;
- Adjust the left front adjuster rod , right adjuster rod and right rear adjuster rod keep the deck in touch with the blocks;
- Adjust the lift rod keep the deck in touch with the blocks.

On the flat lawn, if need, you can change the position of wheel to obtain a lower cut.

### IMPORTANT

Where the lawn is uneven or mossy, you must set the wheel in the hole «A». In case of any doubts, do not hesitate to contact your retailer.

## 6.4 DISMANTLING AND REPLACEMENT

### 6.4.1 Replacing wheels

Stop the machine on flat ground and put a block under a load-bearing part of the frame on the side that the wheel is to be changed.

### NOTE

The wheels are held by a snap ring which can be eased off with a screwdriver. If you have to replace one or both rear wheels, they have the same diameter, and check that cutting deck is horizontal to prevent an uneven cut. You must make sure the key and washer are securely lodged in place.

### IMPORTANT

Before remounting the wheel, apply grease to the axle. Put the snap ring and supporting washer back in place.

### 6.4.2 Replacing and repairing the tyres

The tyres are “Tubeless” and so all punctures must be repaired by a tyre repairer following the procedures required for this kind of tyre.

### 6.4.3 Replacing a fuse

The machine is fitted with 10A fuses. If it blows, the machine stops , the dashboard light switches off. and the battery gradually runs out, the machine will have problems starting. Remove the fuse and replace with a same fuse type.

### IMPORTANT

A blown fuse must always be replaced by one of the same type and ampere rating, and never with one of another rating.

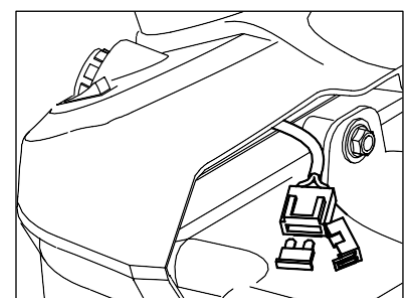
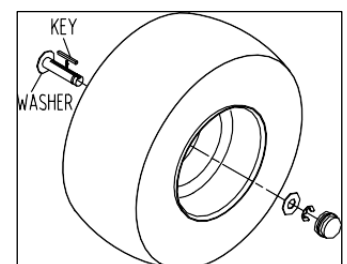
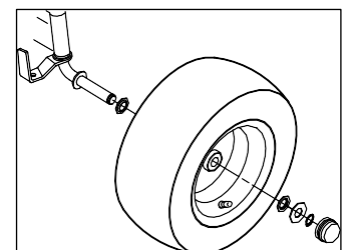
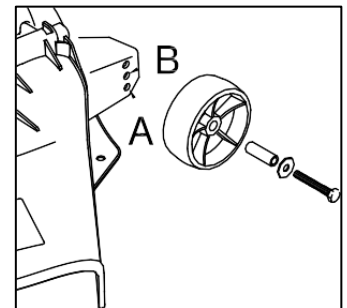
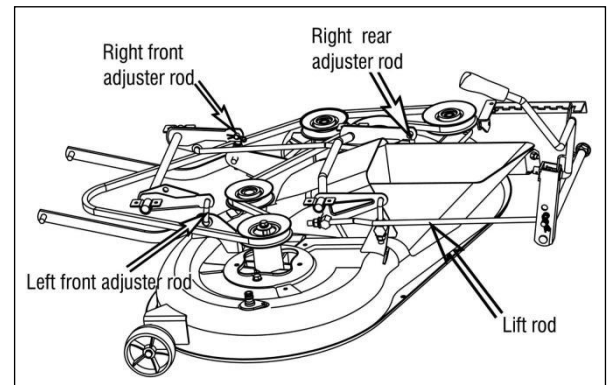

#### 6.4.4 Dismantling, replacing and remounting the blades

**▲ WARNING!**

Always wear work gloves when handling the blades. Before you inspect or remove the blade, stop the engine and disconnect the wire to the spark plug.

**▲ WARNING!**

Damaged or bent blades must always be replaced; never try to repair them!

#### ALWAYS USE ORIGINAL BLADES

Make sure the blades are correctly balanced. The blades are different and rotate in different directions, so make sure you put them back in the right place by referring to the code stamped on the outside of each blade.

#### Step 1 – Removing the Blades

- 1a - screw with right thread (loosen anti-clockwise)
- 1b - screw with left thread (tighten clockwise)

#### Step 2- Refitting the Blades

Check that the concave part of the cushion disc (3) presses against the blade. Remount the shaft hubs (4), making sure that the keys (5) are securely lodged in place.

#### Step 3 - Tightening the Bolts

- 1a = screw with right thread (tighten clockwise)
  - 1b = screw with left thread (tighten anti-clockwise)
- Tighten with a torque wrench calibrated to 40-45 Nm.

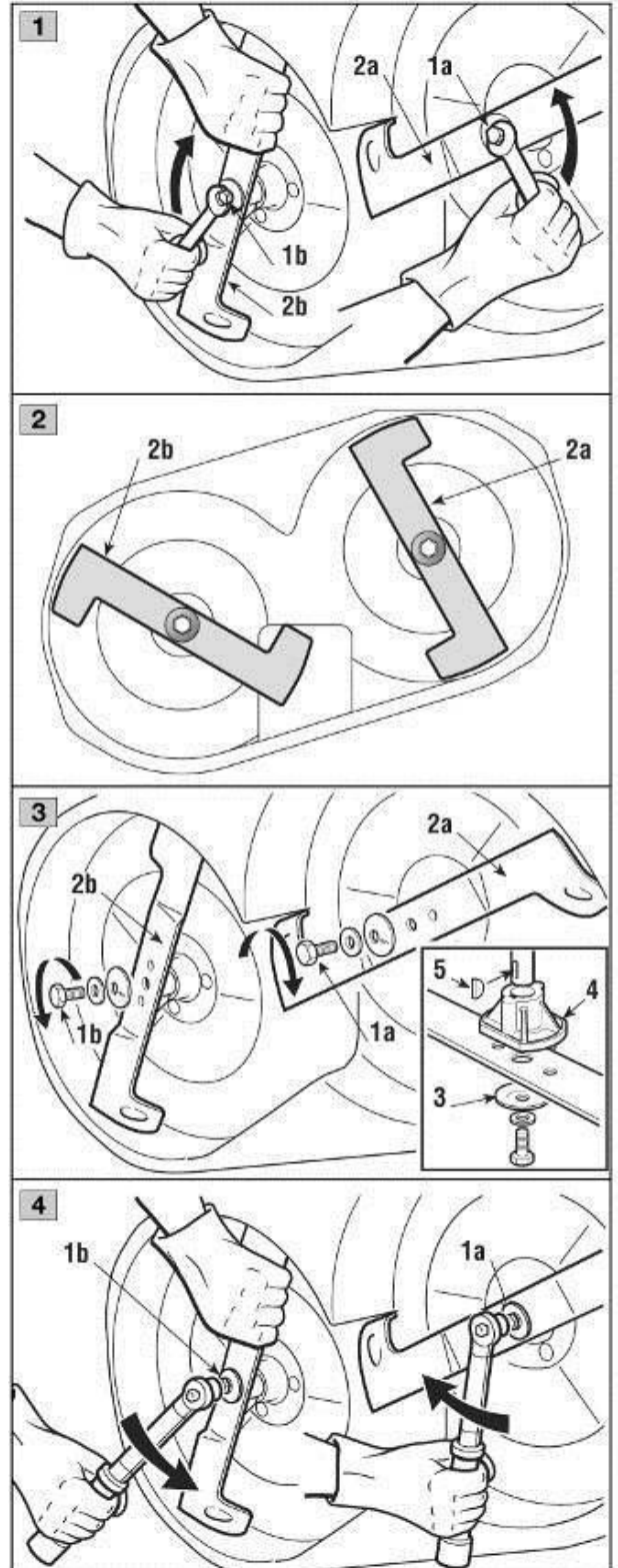

#### 6.4.6 Replacing the belt

The belt replacement must be carried out at a Cobra Service Centre. Replace the belts as soon as they show obvious sign of wear!

**▲ WARNING!**

**ALWAYS USE GENUINE REPLACEMENT BELTS!**

---

## 6.5 LUBRICATION

Apply grease with an injector to the areas shown. apply two or three shots of grease, and wipe off excess grease. Lubricate the areas shown with engine oil. Wipe the area clean, apply a few drops of oil, then wipe up drips or spills.

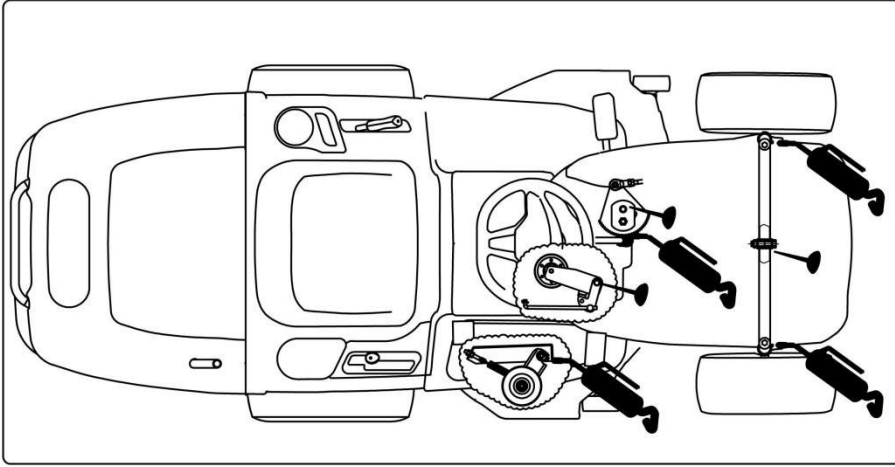

**IMPORTANT**

Do not dirty the belt or brake shoe or tire with the grease or oil. Lubricants will damage these components.

## 7 TROUBLESHOOTING

**⚠ WARNING!** Danger Injury hazard if engine is started inadvertently

Protect yourself against injury. Before carrying out any work on this mower:

- Switch off the engine.
- Remove the ignition key.
- Engage the parking brake.
- Wait until all moving parts have come to a standstill and the engine has fully cooled.
- Pull the spark plug connector off the engine so that the engine cannot accidentally be started.

Faults which occur while you are using your mower often have simple causes, which may corrected by the operator. If you are in any doubt however, your dealer or service center will be happy to provide assistance.

Problem	Possible cause(s)	Remedy
<b>Lighting does not function</b>	1. Headlight wire connector not connected.	Stop the key to «STOP» position and connect the headlight wire.
	2. Bulbs defective.	Stop the key to «STOP» position and replace the bulbs.
	3. Battery not connected correctly.	Connect red cable to the (+) battery terminal and black cable to (-) battery terminal. (par. 3.4)
	4. Ignition switch defective	Replace ignition switch
	5. Battery defective	Test and recharge or replace the battery
	6. Short-Circuit in wire harness	Contact your Dealer or Service center
Problem	Possible cause(s)	Remedy
<b>Start motor will not turn engine</b>	1. Starting conditions have not been met	Check that all starting conditions are met (par. 5.4.1)
	2. No fuel in fuel tank.	Stop the key to «STOP» position and refuel the fuel tank.
	3. Poor contact between cable and battery pole.	Check the connections. (par. 3.4)
	4. Battery flat or defective	Test and recharge or replace the battery.
	5. Fuse defective.	Replace fuse. If the fuse blows repeatedly, determine the cause (usually a short-circuit). (par. 6.4.3)
	6. Clogged air filter	Clean air filter.
	7. Spark Plug defective.	Check the connection of spark plug socket, clean or replace the spark plug.
	8. Brake pedal defective.	Contact your Dealer or Service center.
	9. Clutch/brake switch not pushed down.	Press the PTO Button to the OFF position. (par. 4.3)
	10. Start relay defective	Replace the start relay.

	11. Ignition switch start defective	Replace ignition switch start.
--	-------------------------------------	--------------------------------



<b>Problem</b>	<b>Possible cause(s)</b>	<b>Remedy</b>
<b>Engine runs unevenly</b>	1. Carburetor problem	Contact your Dealer or Service center.
	2. Air filter blocked.	Clean or replace the air filter.(See engine manual)
	3. Fuel tank ventilation blocked.	1. Check and replace the fuel filter if necessary;(see engine manual or contact your Dealer or Service center.) 2. Empty the fuel tank and refuel with fresh fuel;
	4. Grass is too high	Reduce the travelling speed according to the height of the grass and/or raise the cutting height.
<b>Engine operating at reduced power</b>	1. Air filter blocked.	Clean or replace the air filter. (See engine manual)
	2. Engine speed too low	Increase throttle.
	3. Travelling speed too high.	Set to a lower travelling speed.
	4. Spark Plug defective.	Replace the spark plug; see engine manual.
	5. Fuel tank ventilation blocked	1. Check and replace the fuel filter if necessary;(see engine manual or or contact your Dealer or Service center.) 2. Empty the fuel tank and refuel with fresh fuel;

<b>Problem</b>	<b>Possible cause(s)</b>	<b>Remedy</b>
<b>Battery does not charge</b>	1. Fuse defective.	Replace fuse. If the fuse blows repeatedly, determine the cause (usually a short-circuit). (par. 6.4.3)
	2. Poor contact between battery poles and cables.	Check the connections.(par. 3.4)
<b>Machine doesn't move</b>	1.Brake is engaged	Keep the brake pedal pressed down and release the parking brake, release the brake pedal slowly to start forward movement of the machine. (par. 5.4.2)
	2. Gearbox disengaged ( Hydrostatic Gear)	Engage the gearbox. (par. 5.3.5)
	3.Drive belt detached	Fit belt in place .
	4.Drive belt defective or worn	Replace drive belt.
<b>Strong vibrations</b>	1. Blades loose.	Check and tighten all the blades ( see Torque tightening par. 6.4.4) or contact your Dealer or Service center.

<b>Strong vibrations</b>	2. Engine loose.	Check and tighten all the engine and frame bolts
	3. Unbalance in one or both blades resulting from damage.	Contact your Dealer or Service center.
	4. Cutting-deck assembly is full of grass	Clean the cutting-deck assembly
	5.Engine mounting not securely tightened	Tighten engine mounting or contact your Dealer or Service center.
	6. Belt damaged	Replace Belt

<b>Problem</b>	<b>Possible cause(s)</b>	<b>Remedy</b>
<b>Uneven or poor cutting results</b>	1. Blades blunt or worn	Sharpen or replace mowing blades
	2. Different air pressures in tires on left and right side.	Check the tyre pressure.(par. 5.3.2)
	3.Cutting deck adjustment.	Check deck adjustment (6.3 or Contact your Dealer or Service center)
	4.Long and/or wet grass	Adapt cutting level and driving speed to the mowing conditions.
	5.Travelling speed too high.	Set to a lower travelling speed.
	6. Grass stuck under cutting deck	Cleaning inside the deck properly (Use a suitable accessory to access the cleaning of the cutting deck)
	7.Cutting drive belt Slipping	Replace the cutting drive belt
	8.Collector channel is blocked.	Remove the grass catcher and empty the discharge chute

**If problems persist after having performed the above operations, contact your Dealer or Service center.**

## 8 SPECIFICATIONS

Model	LT86MRL (TTM86M)	LT86HRL (TTM86H)	LT92HRL (TTM92H)	LT102HRL (TTM102H)	
Engine model	LC1P85FA	LC1P85FA	LC1P92F-1	LC1P92F-1	
Engine displacement	352 cm <sup>3</sup>	352 cm <sup>3</sup>	452 cm <sup>3</sup>	452 cm <sup>3</sup>	
Nominal power:	7.2 kW	7.2 kW	9.2 kW	9.2 kW	
Max. engine speed	2800min <sup>-1</sup>				
Cutting width	86 cm	86 cm	92 cm	102 cm	
Sound pressure level at the operator	L <sub>pA</sub> : 85.2 dB(A), K <sub>pA</sub> : 3 dB(A)	L <sub>pA</sub> : 85.2 dB(A), K <sub>pA</sub> : 3 dB(A)	L <sub>pA</sub> : 85.6 dB(A), K <sub>pA</sub> : 3 dB(A)	L <sub>pA</sub> : 85.1 dB(A), K <sub>pA</sub> : 3 dB(A)	
Guaranteed sound power level (2000/14/EC)	L <sub>WA</sub> : 100 dB(A)				
Vibration	Hand-arm	a <sub>h</sub> : 3.54 m/s <sup>2</sup> , K <sub>h</sub> : 0.22 m/s <sup>2</sup>	a <sub>h</sub> : 3.24 m/s <sup>2</sup> , K <sub>h</sub> : 0.22 m/s <sup>2</sup>	a <sub>h</sub> : 2.99 m/s <sup>2</sup> , K <sub>h</sub> : 0.07 m/s <sup>2</sup>	a <sub>h</sub> : 2.99 m/s <sup>2</sup> , K <sub>h</sub> : 0.07 m/s <sup>2</sup>
	Whole body	a <sub>h</sub> : 2.85 m/s <sup>2</sup> , K <sub>h</sub> : 0.18 m/s <sup>2</sup>	a <sub>h</sub> : 2.85 m/s <sup>2</sup> , K <sub>h</sub> : 0.18 m/s <sup>2</sup>	a <sub>h</sub> : 2.66 m/s <sup>2</sup> , K <sub>h</sub> : 0.11 m/s <sup>2</sup>	a <sub>h</sub> : 2.66 m/s <sup>2</sup> , K <sub>h</sub> : 0.11 m/s <sup>2</sup>
Mass	184 kg	183 kg	192 kg	188.5 kg	
Driving speed	Forward:1.6-7.5 km/h (5 gears), Reverse 2.5 km/h	Forward:0-8.8 km/h, Reverse 0-4.5 km/h			

Blade Sizes	Left side	Right side
86cm	193401130101	193401130102
92cm	D36.0101.0101	D36.0101.0201
102cm	D40.0106.0405	D40.0106.0602

Specification	For all models
Blade screw tightening torque	40–45 Nm
Cutting height (on 7 levels)	30 – 90 mm
Front wheels	15 × 6.00-6
Rear wheels	18 × 8.50-8
Front wheel inflation pressure	1.0 bar
Rear wheel inflation pressure	1.2 bar
Electrical system	12 Vd.c.
Battery	18 Ah
Min. turning radius	45 cm
Capacity of fuel tank	7.5 L

## 8.1 Machine Dimensions

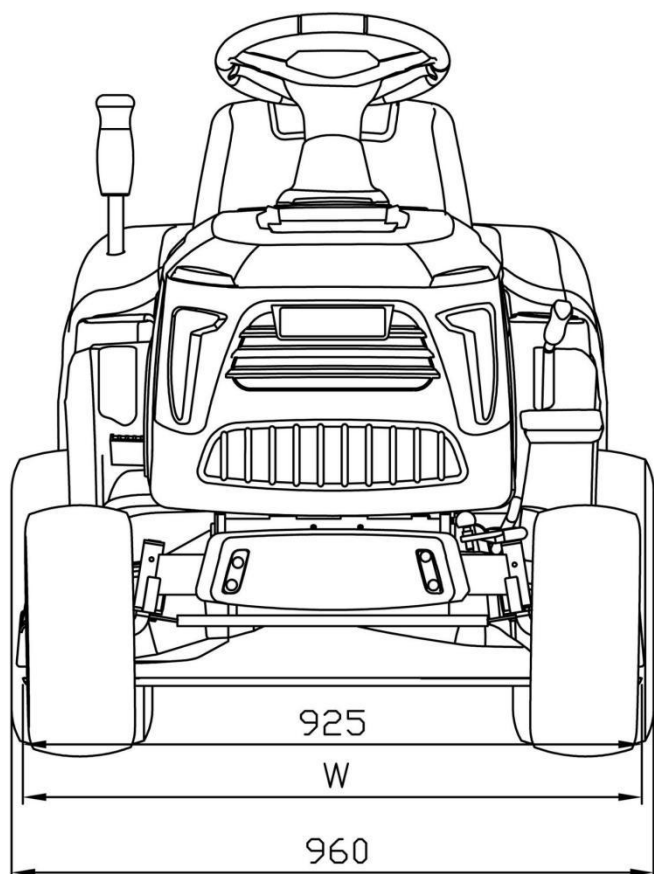
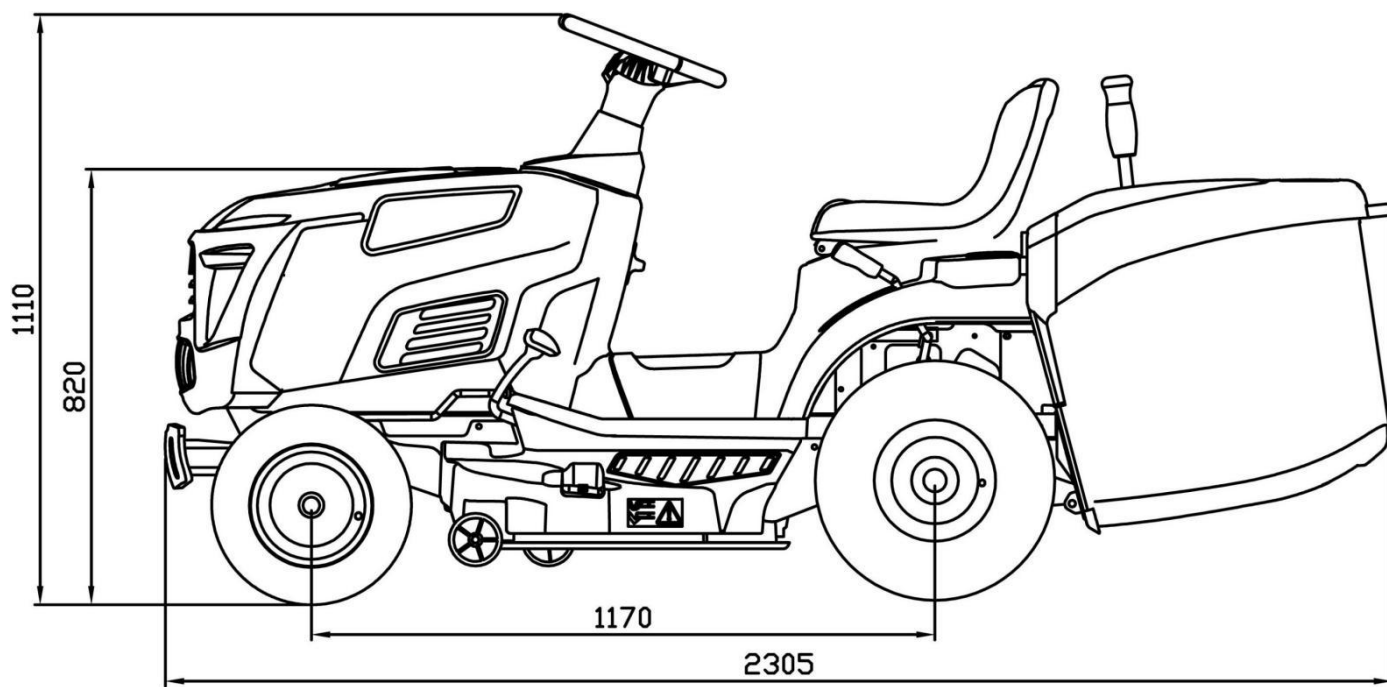

Model	86cm Series	92cm Series	102cm Series
W(mm)	930	980	1080

---

## 9 WARRANTY

This product is warranted in accordance with legal regulations for a 24 month period effective from the date of purchase by the first user. A further 36 months limited warranty is available subject registration, reasonable homeowner use and annual servicing by an approved Cobra dealer and the conditions outlined below. The Cobra dealer will require evidence that the annual services were completed through-out the period of ownership for the warranty to be extended.

This product will not be covered if used in a commercial application.

This warranty covers all material or production failures, it does not include: defects from normal wear and tear, parts such as, bearings, brushes, cables, air cleaning elements, brake pad, clutch disc, tyre, wheel, recoil starter rope, belts, cutter blades, blade bosses, plugs, lubricant oils and grease or accessories. Damage or defects resulting from abuse, accidents or alterations, natural fading of painted or plated surfaces, sheet peeling and other natural deterioration.

Any damage that occurs from the use of non-genuine Cobra parts will not be covered.

We reserve the right to reject any claim where the purchase cannot be verified or when it is clear that the product was not maintained properly. (Clean ventilation slots, carbon brushes and serviced regularly)

Expenses incidental to the warranty claim that are not covered;

- Compensation for loss of time, commercial loss or rental costs of substitute product.
- Costs incurred for transportation to and from the dealership.

Any damage that occurs from the following will not be covered; exposure of the product to smoke and soot, chemical agents, bird droppings or other animal waste, seawater, sea breeze, salt or other environmental phenomena.

Any damage resulting from operating methods other than those indicated in the owner's manual will not be covered.

Your purchase receipt must be kept as proof for date of purchase. Your un-dismantled tractor must be returned to your dealer in an acceptably clean state, accompanied by your proof of purchase.

### **Please Register Your Tractor**

If your dealer did not collect registration information from you, please take a few minutes and register your purchase with Cobra. You can register by completing and mailing the registration card that should be in the box or by going online to:

[www.cobragarden.co.uk](http://www.cobragarden.co.uk) and clicking on Product Registration.



## 10. EC-DECLARATION OF CONFORMITY

<b>EC Declaration of Conformity</b>	
We herewith declare,	Cobra Garden Machinery Henton & Chattell Ltd, London Road, Nottingham NG2 3HW UK
That the following machine complies with the appropriate basic safety and health requirements of the EC Directive based on its design and type, as brought into circulation by us.	
In case of alteration of the machine, not agreed upon by us, this declaration will lose its validity	
Product	Ride-on lawnmower for mowing garden lawns
Machine Type:	LT86MRL (TTM86M), LT86HRL (TTM86H) ,LT92HRL (TTM92H), LT102HRL (TTM102H)
Rated power	LT86MRL (TTM86M) – 7.2kW at 2,800 min <sup>-1</sup> LT86HRL (TTM86H) – 7.2kW at 2,800 min <sup>-1</sup> LT92HRL (TTM92H) – 9.2kW at 2,800 min <sup>-1</sup> LT102HRL (TTM102H) – 9.2kW at 2,800 min <sup>-1</sup>
Measured sound power level:	LT86MRL (TTM86M) – 98.2 dB(A) LT86HRL (TTM86H) – 98.2 dB(A) LT92HRL (TTM92H) – 98 dB(A) LT102HRL (TTM102H) – 96.1 dB(A)
Guaranted sound power level:	100 dB(A) Notified Body for EC Directive 2000/14/EC:0359 M8A 076672/ TÜV SÜD Product Service GmbH/ Ridlerstraße 65 • 80339 Munich • Germany
Applicable EC Directives:	2014/30/EU 2006/42/EC 2000/14/EC 2011/65/EU 2016/1628/EU
Commission Delegated Regulation	2017/654 amended by (EU) 2018/989 2017/655 amended by (EU) 2018/987 2017/656 amended by (EU) 2018/988
Applicable Harmonized Standards:	EN ISO 5395-1:2013+A1, EN ISO 5395-3:2013+A1+A2
Technical standards/ specifications :	EN ISO 12100:2010, EN ISO 14982:2009
Authorized Signature/Date:	  2/2/2023
Title of Signatory:	Managing Director
Name and address of the person authorised to compile the technical file	Cobra Garden Machinery Henton & Chattell Ltd, London Road, Nottingham NG2 3HW UK